



Chassis



Modular



Switches



Small Form



Miniature



Product Catalog 2010

Making Your Net *Work* Better — Since 1988





Company Overview

Since 1988, IMC Networks has set a standard as a “Made in the USA” manufacturer of a variety of specialized and industrial-grade fiber media conversion and fiber optic access solutions for Enterprise, Government and Service Providers’ LANs, First-Mile FTTx networks and Metropolitan Area Networks, delivering 21 years of excellence in product quality, customer satisfaction and value.

With over one million products shipped, IMC Networks’ products are deployed where copper to fiber, dual to single-fiber or Multi-mode to Single-mode fiber conversions are required, carrying both managed and unmanaged media converter modules that support 10, 100, 10/100, 10/100/1000 and Gigabit Ethernet, T1/E1, DS3/E3 and SFP. IMC Networks’ products are sold through a worldwide network of authorized distributors, resellers and OEM partners in more than 50 countries. IMC Networks is ISO 9001:2000 registered; all products are RoHS compliant, Made in the USA, and carry a 6 year comprehensive warranty (SFP products offer a 1 year warranty).

Product Overview

IMC Networks’ media conversion solutions are available in a variety of form factors and configurations that allow networks to perform better, faster and more reliably; from low-cost standalone units to rack-mountable modules designed for high-density applications. The products in this catalog are organized by the following sections:

- Optical Access/FTTx products allow fiber network operators to deliver next-generation Managed Ethernet, high-speed Internet, Private line and Transparent LAN services
- Unmanaged Converters allow customers to convert multiple protocols and interfaces, such as 10/100Base-T copper to 100Base-Fx fiber

- Managed Converters come in a wide range of SNMP-managed devices and variety of protocols including 10/100/1000 Ethernet and T1/E1/J1 range extenders
- Power over Ethernet (PoE) technology allows flexibility in Wireless Access Point and IP camera applications
- Fiber-to-Fiber Mode Converters connect fiber network segments with dissimilar fiber types
- SFPs allow network operators to upgrade fiber types and speeds, preserving the life-span of legacy hardware
- Chassis options support various FTTx and media conversion modules, ranging from single-slot, standalone unmanaged devices to 20-slot, fully-managed rack-mounted chassis
- SNMP iView² Element Management System (EMS) software is available Free of charge

Why IMC Networks?

- Twenty-two years operating since 1988
- Full US operations; manufacturing, marketing & technical support
- Worldwide sales distribution with offices in:
 - Foothill Ranch, CA (West, Worldwide)
 - Clearwater, Florida (East, Latin America)
 - Aarschot/Brussels, Belgium (EMEA)
- Free worldwide technical support
- FCS Complimentary Fiber Consulting Services
- ISO 9001:2008 product quality management
- RoHS environmental compliance
- MEF certification
- Reach EU certification
- 6-year comprehensive warranty (except SFP products are 1-year)
- Made in the USA (except SFP products)

Industry First Innovations

- 16-bit Ethernet LAN card (05/88)
- Ethernet over non-Ethernet cable (07/88)
- Modular repeaters (10/89)
- Media conversion products (09/91)
- Modular hubs (04/95)
- Manageable media converters (09/96)
- Gigabit Ethernet copper-to-fiber converters (04/00)
- Multi-media, multi-protocol chassis platform w/SNMP (11/00)
- USB-powered miniature media converters (12/02)
- Compact Industrial Ethernet optical demarcation device (08/06)

Table of Contents

- » Product Overview 1
- » Quick Product Search Matrix..... 2
- » Product Features 3



Optical Access/FTTx Products

- » AccessEtherLinX 4
- » iMcV-FiberLinX-II..... 5
- » iMcV-Giga-FiberLinX-II..... 6
- » IE-MiniFiberLinX-II 7

Unmanaged Media Conversion Products

- » MiniMc, MiniMc SFP and IE-PowerTray/18..... 8
- » MiniMc-Gigabit, Giga-MiniMc..... 9
- » IE-MiniMc & IE-Giga-MiniMc 10
- » PD-Switch 11
- » McBasic Series 12
- » PSE-McBasic 13
- » AccessConverter 14
- » Mc Module Series (McPIM, McLIM, McGigabit) 15
- » McPC Series 16
- » McPC-MediaLinX Series..... 17
- » McPC-Gigabit Series..... 18
- » WDM Series..... 20

Managed Media Conversion Products

- » iMcV-PIM, iMcV-LIM Modules..... 20
- » iMcV-Giga-MediaLinX Modules 21
- » iMcV-MediaLinX, iMcV-Giga-MediaLinX Modules 22
- » iMcV-T1/E1/J1 Series (Standard & LineTerm) 23
- » iMcV-DS3/E3/STS (Standard or LineTerm)..... 24
- » iMcV-E1-Mux/4, iMcV-E1-Mux/4+Ethernet..... 25
-  » iMcV-Switch..... 26
- » iMcV-PSE-MidSpan..... 27
-  » IE-iMcV-VDSL2 28

Mode Converters

- » iMcV Fiber Mode Converters..... 29
- » IE-ModeConverter SFP/SFP..... 30
-  » IE-iMcV-ModeConverter 31

IE SFP Products

- » IE-SFP 100 to 155 Mbps (OC-3) Transceivers 32
- » IE-SFP 1.25 Gbps (OC-12) Transceivers..... 33
- » IE-SFP 2.4 Gbps (OC-48) Transceivers..... 34
- » IE-XFP 10 Gbps (OC-192) Transceivers 34

Chassis Products

Managed Chassis

- » iMediaChassis 3, 6 and 20 slots 35

Unmanaged Chassis

- » MediaChassis 36
- » MediaConverter 36
- » IE-MediaChassis..... 36

- » Network Cabling Types 37
- » Glossary 39

Converting the Metric System

Equation to calculate meters and kilometers to miles.

1 m = 0.000621 Miles

1 km = 0.621 Miles

m x 0.000621 = Miles

km x 0.621 = Miles

Metric Conversion Table	
100 m =	0.0621 Miles
550 m =	0.341 Miles
2 km =	1.242 Miles
15 km =	9.315 Miles
20 km =	12.42 Miles
40 km =	24.84 Miles
60 km =	37.26 Miles
70 km =	43.47 Miles
80 km =	49.68 Miles
120 km =	74.52 Miles

Product Overview

About Media Converters

Media Converters connect different types of cabling media, extending transmission distances well beyond the capabilities of twisted pair wiring, and allowing for integration of new fiber-based equipment into non-fiber legacy networks. Conversely, Media Converters also allow operators to preserve their investment in legacy copper-port hardware as more and more legacy copper networks are updated with fiber.

IMC Networks' media conversion solutions are available in a variety of form factors and configurations, from low-cost standalone units to rack-mountable modules designed for high-density applications.

About FTTx & Optical Access

Optical Access and FTTx solutions from IMC Networks integrate traditional media converters with advanced remote management and configuration capabilities, allowing service providers to deliver next-generation, managed, high-speed Internet, Ethernet Private Line and Transparent LAN services to businesses, multi-dwelling units (MDUs) and residential customers. FTTx solutions are also used by Enterprise customers when managed media converters are needed on campus networks.

IMC Networks' solutions are available in a variety of form factors and configurations, ranging from standalone units (CPE), to rack-mountable modules designed for high-density applications.

Solutions Overview

Service Providers

IMC Networks' fiber optic media conversion and optical access solutions can make provisioning of fiber-based services less complex and more affordable.

Modular, chassis-based Central Office (CO) solutions accommodate a variety of managed Ethernet, T1/E1/J1, DS3/E3 fiber extension and FTTx applications from the same platform. Intelligent Customer Premises Equipment (CPE) solutions allow service providers to control, manage and monitor the entire access network

and end points without a visit to the customer's location, reducing operational costs while providing capabilities not commonly found on other Ethernet media converters.

Whether providing Fiber-to-the-Home, Business or Premises, IMC Networks' solutions support distances up to 130 km, and offer single-strand and CWDM optical interfaces. The products work seamlessly with other manufacturers' products to maximize service providers' investment in the existing equipment and fiber network infrastructure.

Enterprise LAN/WAN

Fiber optic media converters make a crucial connection between different cabling types and speeds. Media converters are the most flexible, cost-effective solution for extending network distances and integrating fiber optic cabling into twisted pair structured cabling systems. They increase performance of active equipment and also accelerate legacy network segments to Gigabit speeds.

With solutions ranging from simple, standalone converters to intelligent, SNMP managed systems, IMC Networks provides the industry's widest variety of media and mode converters. These solutions support most Ethernet speeds, cabling types and distances, fitting a wide range of enterprise networking applications including:

- Bringing Fiber-to-the-Desk
- Bridging LAN segments with dissimilar fiber types
- Using PoE (Power over Ethernet) to bring power to network devices such as Wireless Access Points and IP Cameras

Government

The US government has historically been a pioneer in networking research, development and Internet technology. IMC Networks proudly supports federal, state and local governments with fiber solutions that combine high security with greater bandwidth.

IMC Networks is a preferred vendor to government organizations worldwide. In addition to standalone and PC card media converters, IMC Networks also has an extensive line of SNMP-managed media converters that offer increased security.

IMC Networks' fiber mode converters allow network managers to connect multi and single-mode network segments together, simplifying network planning.

IMC Networks proudly provides special pricing and free ground shipping under GSA contract #GS-35F-0491J. Visit <http://www.imcnetworks.com/Government/> for more information.





Why Fiber Optics?

Fiber is most commonly associated with long distance connections. Today, however, it is rapidly gaining market share in LAN topologies, once considered the domain of copper cabling. Fiber offers many advantages:

- It has exceptional bandwidth, and can carry multiple signals concurrently
- It is immune to electromagnetic interference
- It has no electromagnetic emissions, making it resistant to eavesdropping
- It is lightweight
- It is virtually "future proof"

Quick Product Search Matrix

Products Featured in This Catalog		IE	Protocol							Ports				Format		SNMP		Page		
		Industrial Ethernet	10 Mbps Ethernet	100 Mbps Ethernet	1000 Mbps Ethernet	2.4 Gbps Ethernet	Protocol Independent *	T1/E1/J1	DS3/E3/STS-1	WDM	Fiber	Copper (RJ-45)	PoE (RJ-45)	SFP	Coaxial (BNC)	Standalone	Modular	Managed	Unmanaged	
FTTx	AccessEtherLinX **		•	•						•	•				•		•		4	
	iMcV-FiberLinX-II **		•	•						•	•		•			•	•		5	
	iMcV-Giga-FiberLinX-II **		•	•	•					•	•		•			•	•		6	
	IE-MiniFiberLinX-II **	•	•	•						•	•				•		•		7	
Media Conversion	MiniMc, MiniMc SFP **		•	•						•	•		•		•	•		•	8	
	Giga-MiniMc, MiniMc-Gigabit		•	•	•					•	•				•	•		•	9	
	IE-MiniMc, IE-Giga-MiniMc **	•			•					•	•				•	•		•	10	
	PD-Switch		•	•						•	•	•	•		•			•	11	
	McBasic Series		•	•	•					•	•		•		•			•	12	
	PSE-McBasic			•						•	•	•			•			•	13	
	AccessConverter **		•	•						•	•				•			•	14	
	McPIM		•							•	•					•		•	15	
	McLIM **			•						•	•					•		•	15	
	McLIM Switching		•	•						•	•					•		•	15	
	McGigabit				•					•	•					•		•	15	
	McPC 100 Mbps			•						•	•					•		•	16	
	McPC 10/100 **		•	•						•	•					•		•	16	
	McPC Switching		•	•						•	•					•		•	17	
	McPC-Gigabit				•					•	•					•		•	18	
	WDM								•	•					•	•		•	19	
	Managed Modular Converters	iMcV-PIM		•							•	•					•	•		20
		iMcV-LIM			•						•	•					•	•		20
iMcV-LIM 10/100			•	•						•	•					•	•		20	
iMcV-Gigabit					•					•	•					•	•		21	
iMcV-MediaLinX **			•	•						•	•					•	•		22	
iMcV-Giga-MediaLinX **			•	•	•					•	•					•	•		22	
iMcV-T1/E1/J1							•			•	•					•	•		23	
iMcV-DS3/E3/STS								•		•	•			•		•	•		24	
iMcV-E1-Mux/4, iMcV-E1-Mux/4 + Ethernet							•			•	•		•		•	•			25	
iMcV-Switch 			•	•						•	•		•			•	•		26	
iMcV-PSE-MidSpan			•	•						•	•	•				•	•		27	
IE-iMcV-VDSL2 	•	•	•							•					•	•		28		
iMcV-S2MM, S2SM, M2MM						•			•						•	•		29		
IE-ModeConverter	•					•						•		•			•	30		
IE-iMcV-ModeConverter 	•					•						•		•			•	31		
Other	IE-SFP	•	•	•	•							•							32-34	
	Chassis																•	•	35-36	

* Protocol Independent ranges from 10 Mbps to 1.25 Gbps
 ** Rate conversion option available



Autocross

Autocross allows for automatic detection of the correct MDI-II / MDI-X configuration on the copper ports (RJ-45), eliminating the need to specify different cables (crossover or straight-through) and thus eliminating another step in troubleshooting.



Auto Negotiation

Auto Negotiation allows devices to automatically assign the most efficient line speed (10/100/1000 Mbps) and mode (Full-Duplex or Half-Duplex) for a particular network segment between two devices.



Coarse Wave Division Multiplexing

Coarse Wave Division Multiplexing (CWDM) uses uncooled lasers to combine multiple wavelengths (four, eight or 16; from 1310 nm to 1610 nm) onto a single fiber, using an ITU standard 20nm spacing between the wavelengths. Adding wavelengths to the same fiber increases capacity, making CWDM technology a sound choice for large networks such as Gigabit Ethernet and Fibre Channel-based Metropolitan Area Networks (MAN).



FiberAlert

FiberAlert minimizes the problems associated with the loss of one strand of fiber. If a strand is unavailable, the device at the receiver end notes the loss of link. The device will then stop transmitting on the fiber until a signal or link pulse is received. The result is that the link LED on BOTH sides of the fiber connection will go out indicating a fault somewhere in the fiber loop.



Industrial Ethernet (IE)

IE stands for "Industrial Ethernet" and refers to IMC Networks' designation for products that have been designed to operate in a wider temperature range rather than the typical 0°C to +40°C. IMC Networks' "IE" products contain additional features designed for industrial applications, such as multiple powering options and DIN clips. IE temperature ranges vary, so check the product specifications for more details.

IE products require third party enclosures for outdoor installations or protection from moisture, dust and other harsh environmental factors. External protection is also required for lightning or other serious power surges.



Last Gasp

The Last Gasp feature available on select IMC Networks modules allows for one final health status message to be sent when remote modules lose power, notifying network operators that a field visit is necessary.

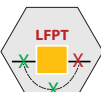

Link Fault Pass-Through (LFPT)

LFPT (Link Fault Pass-Through) – A feature that allows a segment of a network, divided by a media converter, to act as if it was one physical piece of media. It does this by passing a link fault from one side of the media converter to the other. If a link is lost on one side of the media converter the converter forces a link fault on the other.



LinkLoss

LinkLoss is a troubleshooting feature that works on either the twisted pair port (TP/TX) or the fiber port (FO/FX) of devices which have at least one of each port type. When a fault occurs on one segment of a conversion, LinkLoss detects the fault and passes this information to the other segment. For example, if a media converter is not receiving a fiber link, FO/FX LinkLoss disables the transmitter on the media converter's twisted pair port. This results in a loss of link on the remote twisted pair device.



Managed Products

IMC Networks offers several products that support SNMP management, allowing operators to proactively manage and monitor their devices from a remote location.



On Board SNMP Management

IMC Networks offers "intelligent" products with on board SNMP management, allowing operators to proactively manage and monitor the devices without an additional management controller.



Power Over Ethernet (PoE)

Power Over Ethernet (PoE) is a standards based (IEEE 802.3af) method of delivering power over twisted-pair network cables (RJ-45) along with data, thus eliminating the need for a separate run for a power source. There are two types of PoE devices: the Power Sourcing Equipment (PSE) and the Powered Device (PD). The PSE supplies power to the PD.



Q-in-Q

Q-in-Q, also known as Extra-Tagging, is an IEEE 802.1Q compliant method of assigning a VLAN tag to already tagged network traffic. Q-in-Q enables the transmission of data across multiple VLANs without altering the original data, providing safer and more secure transmission of data packets over the network.



RoHS

With environmental protection becoming more important across the globe, IMC Networks has taken a leadership position by designing products that are free of lead, cadmium and 6 other toxic materials. This makes the products of IMC Networks compliant with the Restriction of Hazardous Substances in Electrical and Electronic Equipment Directive (RoHS), passed into law by the European Union. All part numbers starting with "8" are RoHS compliant.

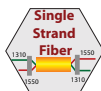

Single-Strand Fiber

Single-Strand Fiber technology allows two wavelengths to share one fiber strand. Full-Duplex data travels on different wavelengths (1310 nm and 1550 nm) which effectively doubles the capacity of installed fiber. Since single-strand fiber products use optics that transmit and receive on two different wavelengths, single-strand fiber products must be deployed in pairs. The pair can consist of two IMC or third-party products that conform to the same IMC standard.

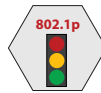

Traffic Prioritization

Traffic Prioritization (IEEE 802.1p) provides advanced packet management of network traffic by assigning a priority ID to each packet, insuring that high-priority traffic (such as VoIP) receives the network resources and bandwidth necessary for high Quality of Service (QoS).



Unified Management Agent (UMA)

The Unified Management Agent (UMA) is a proprietary system developed by IMC Networks to utilize a separate management domain on the network in order to keep management and other data separate. UMA is an IP-less management method which simplifies management of supported devices by reducing the number of IP addresses.



VLAN Tagging

VLAN Tagging (IEEE 802.1Q) involves assigning identification information to data packets on a network to insure that data is efficiently and correctly routed between devices. The VLAN tag includes an EtherType, priority bits and a VLAN ID that allows each packet to remain secure and intact while being routed across multiple networks.

AccessEtherLinX/4



Managed multi-port optical demarcation devices combining media conversion with advanced capabilities.

Product Overview

The AccessEtherLinX/4 enables service providers to offer differentiated, bandwidth-scalable data or "Transparent LAN" services to multi-tenant buildings and business customers. Residing at the customer premises, the AccessEtherLinX/4 provides a VLAN-based, Layer 2 entry point to the last mile fiber network, trunking, differentiating and separating customer traffic.

The AccessEtherLinX/4 features SNMP management, bandwidth control, VLAN tagging, traffic prioritization and IGMP multicast pruning/snooping with support for 4 customer ports. It provides an ideal and cost effective solution for delivering Ethernet-based services to business customers.

Choose from a variety of brackets and rackmounting options for easy installation.

Application Example

For residential and commercial fiber services, install the AccessEtherLinX/4 inside the customer premises to provide a demarcation point between the customer and service provider networks.

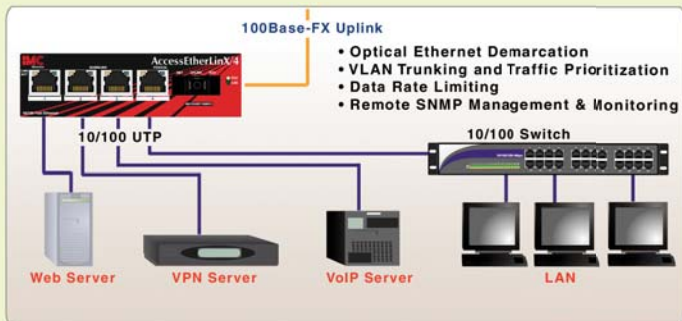

Features

- Fiber or copper uplink options
- Independent RJ-45 ports for flexible configurations
- Easy to configure and manage with GUI-based iView²
- Can be managed using Telnet
- Includes DHCP and TFTP client
- Includes SNMP V2c
- Read/write IEEE 802.1Q VLAN-tags
- Bi-directional bandwidth control
- IEEE 802.3x compliant for Flow Control
- QoS – IEEE 802.1p-based packet prioritization
- Includes loopback test modes
- MAC address learning
- Includes LinkLoss and FiberAlert
- Selective Advertising
- Half and Full-Duplex operation
- Remote management and upgrades
- Supports IGMP multicast pruning/snooping

Physical Specifications

Fiber Types Supported

- 50/125µm or 62.5/125µm multi-mode fiber
- 9/125µm single-mode fiber
- Available for single-strand fiber and CWDM fiber wavelengths
- AutoCross for automatic MDI-II/MDI-X switching

Connectors:

RJ-45, ST and SC

Regulatory Approvals:

FCC Class B, UL/cUL, CSA, CE

Operating Temperature:

+32° to +122°F (0° to +50°C)

Storage Temperature:

-13° to +158°F (-25° to +70°C)

Humidity:

5 to 95% (non-condensing)

Altitude:

0 to 10,000 ft.

Dimensions

1.5" H x 4.75" W x 7.25" D
(3.18 cm x 12.07 cm x 18.42 cm)

Power Rating

100-240V AC, 50/60Hz, 1A

Shipping Weight:

1.6 lbs. (0.6 kg)

Ordering Information

852-13120	AccessEtherLinX, TX/4 + TX, 100 m
852-13121	AccessEtherLinX, TX/4 + FX-MM1300-ST, 5 km
852-13122	AccessEtherLinX, TX/4 + FX-MM1300-SC, 5 km
852-13123	AccessEtherLinX, TX/4 + FX-SM1310/PLUS-ST, 40 km
852-13124	AccessEtherLinX, TX/4 + FX-SM1310/PLUS-SC, 40 km
852-13125	AccessEtherLinX, TX/4 + FX-SM1310/LONG-ST, 80 km
852-13126	AccessEtherLinX, TX/4 + FX-SM1310/LONG-SC, 80 km
852-13127	AccessEtherLinX, TX/4 + FX-SM1550/LONG-SC, 80 km

Single-Strand Fiber

852-10133	AccessEtherLinX, TX/4 + SSFX-SM1310-SC (1310xmt/1550rcv), 20 km
852-10134	AccessEtherLinX, TX/4 + SSFX-SM1550-SC (1550xmt/1310rcv), 20 km
852-10135	AccessEtherLinX, TX/4 + SSFX-SM1310/PLUS-SC (1310xmt/1550rcv), 40 km
852-10136	AccessEtherLinX, TX/4 + SSFX-SM1550/PLUS-SC (1550xmt/1310rcv), 40 km
852-10137	AccessEtherLinX, TX/4 + SSFX-SM1310/LONG-SC (1310xmt/1550rcv), 60 km
852-10138	AccessEtherLinX, TX/4 + SSFX-SM1550/LONG-SC (1550xmt/1310rcv), 60 km

Available Accessories

895-39226	Rackmount bracket
895-39949	Rackmount shelf

Rackmount bracket



Rackmount shelf



iMcV-FiberLinX-II



Optical demarcation module enabling delivery of transparent LAN services over fiber with integrated media conversion, carrier-grade remote management and line provisioning capabilities.

Product Overview

The iMcV-FiberLinX-II solution connects two remote networks over fiber optics and allows administrators to observe both the end-points and the fiber link between them, as single management entities and not as separate elements. Host management traffic is not visible to the remote or customer network nor is access to the customer network required, guaranteeing end-to-end data integrity.

The iMcV-FiberLinX-II can be configured remotely, can alert administrators to any potential problems on the long-haul fiber run, can provide vital information on link condition and can report data traffic statistics.

The iMcV-FiberLinX-II end points and fiber link can be managed as a single entity, allowing remote configuration and fault alerts to network administrators. As a copper-to-fiber media converter, it allows low-cost copper switches to connect to the fiber line. Offering unparalleled flexibility, the iMcV-FiberLinX-II supports multiple fiber types including multi-mode and single-mode as well as single-strand fiber, doubling the capacity of installed fiber. Coarse Wavelength Division Multiplexing (CWDM) functionality is also an option.

Application Example

When used in pairs, a module configured as a Host resides at the head-end while another module, configured as a Remote, installs at the remote customer location (typically on the network edge where the customer network meets the service provider infrastructure). Using SNMP, the iMcV-FiberLinX-II solution monitors the entire link and ensures data integrity while remaining isolated and completely transparent to the customer LAN.

Features

- Transparency feature allows VLAN/non-VLAN traffic on the same port
- Provides differential priority
- Set bi-directional bandwidth
- Remotely configure settings
- Last gasp SNMP trap
- Easy to configure and manage with GUI-based iView²
- Includes RJ-45 management port
- Manage/monitor fiber traffic
- Includes RMON statistics
- SNMP V1 and V2c compatible
- Supports the Unified Management Agent (UMA)
- Receive vital health information
- Q-in-Q/Extra-Tagging
- Supports passive 802.3ah OAM (Operation, Administration & Management)

Physical Specifications

Fiber Types Supported

- 50/125µm or 62.5/125µm multi-mode fiber
- 9/125µm single-mode fiber
- Available for single-strand fiber, CWDM fiber and SFP

Connectors:

RJ-45, ST, SC and SFP

Regulatory Approvals:

FCC Class A, UL/cUL, CE, CSA, CB

Operating Temperature:

+32° to +122°F (0° to +50°C)

Storage Temperature:

0° to +160°F (-20° to +70°C)

Humidity:

5 to 95% (non-condensing)

Altitude:

0 to 10,000 ft.

Dimensions

4.19"H x 0.78"W x 2.75"D (10.74 x 2 x 7.05 cm)

Power Consumption:

.850mA at 3.3V DC

Shipping Weight:

0.30 lbs (0.11 kg)

Ordering Information

iMcV-FiberLinX-II, SFP port(s)

856-14500	iMcV-FiberLinX-II, TX/SFP, SFP Variable (requires one SFP/155-ED Module)
856-14501	iMcV-FiberLinX-II, SFP/SFP, SFP Variable (requires two SFP/155-ED Module)

iMcV-FiberLinX-II, TX/TX

856-14010	iMcV-FiberLinX-II, TX/TX, 100 m
-----------	---------------------------------

iMcV-FiberLinX-II, TX/FX

856-14011	iMcV-FiberLinX-II, TX/FX-MM1300-ST, 5 km
856-14012	iMcV-FiberLinX-II, TX/FX-MM1300-SC, 5 km
856-14015	iMcV-FiberLinX-II, TX/FX-SM1310/PLUS-ST, 40 km
856-14016	iMcV-FiberLinX-II, TX/FX-SM1310/PLUS-SC, 40 km
856-14017	iMcV-FiberLinX-II, TX/FX-SM1310/LONG-ST, 80 km
856-14018	iMcV-FiberLinX-II, TX/FX-SM1310/LONG-SC, 80 km
856-14021	iMcV-FiberLinX-II, TX/FX-SM1550/LONG-SC, 80 km
856-14022	iMcV-FiberLinX-II, TX/FX-SM1550/XLONG-SC, 130 km

Single-Strand Fiber

856-14043	iMcV-FiberLinX-II, TX/SSFx-SM1310-SC (1310xmt/1550rcv), 20 km
856-14044	iMcV-FiberLinX-II, TX/SSFx-SM1550-SC (1550xmt/1310rcv), 20 km
856-14045	iMcV-FiberLinX-II, TX/SSFx-SM1310/PLUS-SC (1310xmt/1550rcv), 40 km
856-14046	iMcV-FiberLinX-II, TX/SSFx-SM1550/PLUS-SC (1550xmt/1310rcv), 40 km
856-14047	iMcV-FiberLinX-II, TX/SSFx-SM1310/LONG-SC (1310xmt/1550rcv), 60 km
856-14048	iMcV-FiberLinX-II, TX/SSFx-SM1550/LONG-SC (1550xmt/1310rcv), 60 km

Use with Chassis Platform

iMediaChassis Series, See Page 33
MediaChassis Series, See Page 34
IE-MediaChassis Series, See Page 34

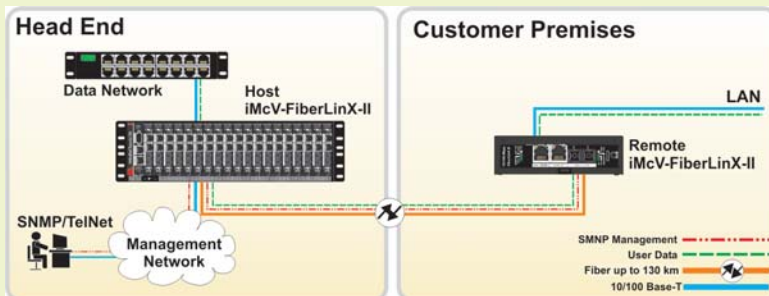

CWDM version available,
Call IMC Networks for details



10/100/1000 Mbps Auto Negotiating Copper (TX), 1.25 Gbps (SX/LX) Gigabit Ethernet

iMcV-Giga-FiberLinX-II

6-YEAR
Comprehensive
Warranty



An optical demarcation unit enabling delivery of transparent LAN services while providing carrier-grade management and line provisioning capabilities.

Product Overview

Service providers who provide Transparent LAN services must be able to remotely manage their customer premises equipment while keeping management and customer data traffic separated. The iMcV-Giga-FiberLinX-II provisions point-to-point fiber optic connections and provides a unique management tool to the entire link between two locations.

Field-proven worldwide since 1999, the iMcV-Giga-FiberLinX-II system is ideal for Optical Ethernet, FTTx and campus area network applications.

The iMcV-Giga-FiberLinX-II solution connects two remote networks over fiber optics and allows administrators to observe both the end-points, and the fiber link between them, as single management entities and not as separate elements. Host management traffic is not visible to the remote or customer network nor is access to the customer network required, guaranteeing end-to-end data integrity. The iMcV-Giga-FiberLinX-II allows for remote configuration and alerts administrators to any potential problems on the long-haul fiber run. It also functions as a copper-to-fiber media converter, allowing deployment of lower cost copper switches at both ends of the fiber connection.

Offering unparalleled flexibility, iMcV-Giga-FiberLinX-II supports multiple fiber types as well as single-strand fiber which can effectively double the capacity of installed fiber. The iMcV-Giga-FiberLinX-II module installs in a standard IMC Networks iMediaChassis series or MediaChassis/2.

Application Example

When used in pairs, a module configured as a Host resides at the head-end while another module, configured as a Remote, installs at the remote customer location (typically on the network edge where the customer network meets the service provider infrastructure). Using SNMP, the iMcV-Giga-FiberLinX-II solution monitors the entire link and ensures data integrity while remaining isolated and completely transparent to the customer LAN.

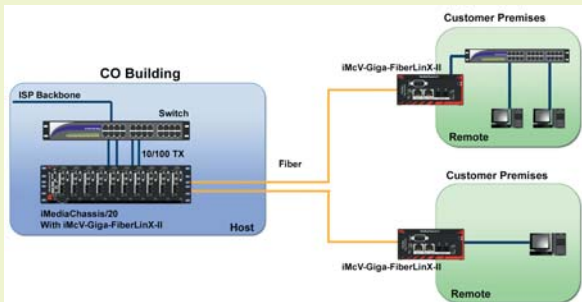

Features

- VLAN-tagging and Q-in-Q (Extra Tagging) segregates customer traffic
- IEEE 802.1Q VLAN and 802.1p compliant
- Transparency feature allows VLAN/non-VLAN traffic on the same port
- Provides differential priority
- Remotely configure settings
- Easy to configure and manage with GUI-based iView²
- Includes RJ-45 management port
- Manage/monitor fiber traffic
- Includes RMON statistics
- SNMP V1 and V2c compatible
- Supports the Unified Management Agent (UMA)
- Supports passive 802.3ah OAM (Operation, Administration & Management)

Physical Specifications

Fiber Types Supported

- 50/125µm or 62.5/125µm multi-mode fiber
- 9/125µm single-mode fiber
- Available for single-strand fiber, CWDM fiber and SFP

Connectors:

RJ-45, ST, SC and SFP

Regulatory Approvals:

FCC Class A, UL/cUL, CE, CSA, CB

Operating Temperature:

+32° to +122°F (0° to +50°C)

Storage Temperature:

-13° to +158°F (-25° to +70°C)

Humidity:

5 to 95% (non-condensing)

Altitude:

0 to 10,000 ft.

Dimensions

Double-wide module

Power Consumption:

850mA at 3.6V DC

Shipping Weight:

0.8 lbs (0.36 kg)

Ordering Information

iMcV-Giga-FiberLinX-II, SFP port(s)

856-14760	iMcV-Giga-FiberLinX-II, TX/SFP (requires one SFP/1250-ED Module)
856-14761	iMcV-Giga-FiberLinX-II, SFP/SFP (requires two SFP/1250-ED Module)

iMcV-Giga-FiberLinX-II, SX/LX

10/100/1000 Mbps

856-14869	iMcV-Giga-FiberLinX-II, TX/SX-MM850-SC, 550 m
856-14870	iMcV-Giga-FiberLinX-II, TX/LX-SM1310-SC, 15 km
856-14871	iMcV-Giga-FiberLinX-II, TX/LX-SM1310/PLUS-SC, 40 km
856-14872	iMcV-Giga-FiberLinX-II, TX/LX-SM1550/LONG-SC, 80 km
856-14881	iMcV-Giga-FiberLinX-II, TX/LX-SM1550/XLONG-SC, 100 km

Single-Strand Fiber

856-14873	iMcV-Giga-FiberLinX-II, TX/SSLX-SM1310-SC (1310xmt/1550rcv), 15 km
856-14874	iMcV-Giga-FiberLinX-II, TX/SSLX-SM1550-SC (1550xmt/1310rcv), 15 km
856-14890	iMcV-Giga-FiberLinX-II, TX/SSBX-SM1310-SC (1310xmt/1490rcv), 10 km
856-14891	iMcV-Giga-FiberLinX-II, TX/SSBX-SM1490-SC (1490xmt/1310rcv), 10 km
856-14875	iMcV-Giga-FiberLinX-II, TX/SSLX-SM1310/PLUS-SC (1310xmt/1550rcv), 40 km
856-14876	iMcV-Giga-FiberLinX-II, TX/SSLX-SM1550/PLUS-SC (1550xmt/1310rcv), 40 km
856-14892	iMcV-Giga-FiberLinX-II, TX/SSBX-SM1310/PLUS-SC (1310xmt/1490rcv), 30 km
856-14893	iMcV-Giga-FiberLinX-II, TX/SSBX-SM1490/PLUS-SC (1490xmt/1310rcv), 30 km
856-14877	iMcV-Giga-FiberLinX-II, TX/SSLX-SM1490/LONG-SC (1490xmt/1550rcv), 70 km
856-14878	iMcV-Giga-FiberLinX-II, TX/SSLX-SM1550/LONG-SC (1550xmt/1490rcv), 70 km
856-14879	iMcV-Giga-FiberLinX-II, TX/SSLX-SM1490/XLONG-SC (1490xmt/1550rcv), 70 km
856-14880	iMcV-Giga-FiberLinX-II, TX/SSLX-SM1550/XLONG-SC (1550xmt/1490rcv), 70 km

Available Accessories

825-39950	Serial Cable
-----------	--------------

Use with Chassis Platform

iMediaChassis Series, See Page 33
MediaChassis/2 (only) Series, See Page 34
IE-MediaChassis/2 (only) Series, See Page 34

CWDM version available,
Call IMC Networks for details



10/100 Mbps Auto Negotiating Copper (TX),
100 Mbps Fiber (FX) Ethernet (MAN, CityNet)

IE-MiniFiberLinX-II



Compact fiber optic CPE for industrial-grade delivery over fiber, with media conversion, carrier grade management and line provisioning capabilities.

Product Overview

The compact IE-MiniFiberLinX-II provides point-to-point fiber optic connections with a unique management tool to monitor the entire link between two locations. IE-MiniFiberLinX-II CPE for fiber optic networks allows service providers to deliver "triple-play" voice, video and data services to customer premises.

As a copper-to-fiber converter, the IE-MiniFiberLinX-II supports multiple fiber types including multi-mode, single-mode, single-strand fiber (SSF), and Course Wavelength Division Multiplexing (CWDM) functionality to increase the capacity of existing fiber. It allows for remote configuration, provides vital alerts to network administrators, and can manage the CPE and fiber link as a single entity.

Equipped with one 100 Mbps fiber data port, one 10/100 twisted pair port for data and management, as well as an auxiliary port designed to function as a serial port (when used with the included adapter), the IE-MiniFiberLinX-II also offers multiple powering options: AC power (with included adapter), DC (through a 4-terminal power block), as well as Power over Ethernet, acting as a Powered Device (PD) to draw power when connected to 802.3af compliant Power Sourcing Equipment (PSE).

Combining copper-to-fiber conversion, extended temperature performance, plug-and-play operation, miniature size and multiple power options, the IE-MiniFiberLinX-II is one of the most versatile fiber optic CPE devices available.

Application Example

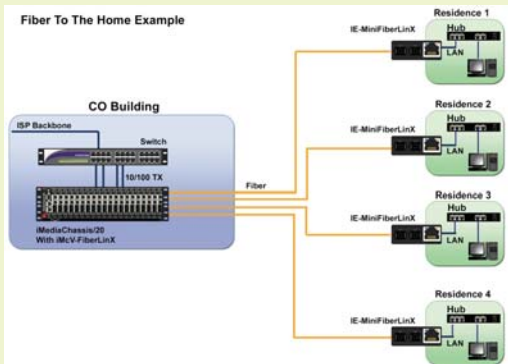

Features

- Loopback troubleshooting
- Power options: AC, DC and 802.3af Power over Ethernet (PoE)
- Preserves complete end-to-end fiber connection integrity
- Includes bi-directional bandwidth control
- Read/write IEEE 802.1Q VLAN-tags
- QoS: IEEE 802.1p-based packet prioritization (2 queues [high/low] with 8 levels of priority)
- Layer 2 packet switching, store and forward operation
- Forwarding rate: 14,880pps for 10 Mbps; 148,800pps for 100 Mbps;
- MTU: Supports over-sized packets up to 1536 bytes
- SNMP V1 and V2c compatible
- Managed via Telnet
- IEEE 802.3x Flow Control
- Includes DHCP and TFTP clients
- Supports the Unified Management Agent (UMA)
- IEEE 802.3 10Base-T twisted pair
- IEEE 802.3u 100Base-TX twisted pair
- IEEE 802.3u 100Base-FX or SX fiber
- Supports passive 802.3ah OAM (Operation, Administration & Management)

Physical Specifications

Fiber Types Supported

- 50/125µm or 62.5/125µm multi-mode fiber
- 9/125µm single-mode fiber
- Available for single-strand fiber, CWDM fiber

Connectors:

RJ-45, ST and SC

Regulatory Approvals:

FCC Class A, UL/cUL, CE, CSA, CB

Operating Temperature:

-4° to +158°F (0° to +70°C) DC Configuration
+32° to +122°F (0° to +50°C) with AC wall adapter

Storage Temperature:

-49° to +185°F (-45° to +85°C)

Humidity:

5 to 95% (non-condensing)

Altitude:

0 to 10,000 ft.

Dimensions

0.85"H x 1.83"W x 3.38"D (2.15 x 4.64 x 8.58 cm)

Power Rating:

AC Wall adapter: 100/240 ±10% VAC input, 50/60 Hz 5V DC output at 10W, 2.0A
DC Input: 7 to 50V DC, 1A-0.1A

Shipping Weight:

0.30 lbs (0.11 kg)

Ordering Information

With AC Power Supply

856-19717	IE-MiniFiberLinX-II, TP-TX/FX-MM850-ST, 2 km
856-19718	IE-MiniFiberLinX-II, TP-TX/FX-MM850-S, 2 km
856-19722	IE-MiniFiberLinX-II, TP-TX/FX-MM1300-ST, 5 km
856-19723	IE-MiniFiberLinX-II, TP-TX/FX-MM1300-SC, 5 km
856-19724	IE-MiniFiberLinX-II, TP-TX/FX-SM1310/PLUS-ST, 30 km
856-19725	IE-MiniFiberLinX-II, TP-TX/FX-SM1310/PLUS-SC, 30 km
856-19726	IE-MiniFiberLinX-II, TP-TX/FX-SM1310/LONG-ST, 80 km
856-19727	IE-MiniFiberLinX-II, TP-TX/FX-SM1310/LONG-SC, 80 km
856-19730	IE-MiniFiberLinX-II, TP-TX/FX-SM1550/LONG-SC, 80 km
856-19728	IE-MiniFiberLinX-II, TP-TX/FX-SM1550/XLONG-SC, 130 km

Single-Strand Fiber

856-19750	IE-MiniFiberLinX-II, TP-TX/SSFx-MM1310-SC (1310xmt/1550rcv), 2 km
856-19751	IE-MiniFiberLinX-II, TP-TX/SSFx-MM1550-SC (1550xmt/1310rcv), 2 km
856-19752	IE-MiniFiberLinX-II, TP-TX/SSFx-SM1310-SC (1310xmt/1550rcv), 20 km
856-19753	IE-MiniFiberLinX-II, TP-TX/SSFx-SM1550-SC (1550xmt/1310rcv), 20 km
856-19754	IE-MiniFiberLinX-II, TP-TX/SSFx-SM1310/PLUS-SC (1310xmt/1550rcv), 40 km
856-19755	IE-MiniFiberLinX-II, TP-TX/SSFx-SM1550/PLUS-SC (1550xmt/1310rcv), 40 km
856-19756	IE-MiniFiberLinX-II, TP-TX/SSFx-SM1310/LONG-SC (1310xmt/1550rcv), 60 km
856-19757	IE-MiniFiberLinX-II, TP-TX/SSFx-SM1550/LONG-SC (1550xmt/1310rcv), 60 km

Without AC Power Supply

856-19740	IE-MiniFiberLinX-II Module, TP-TX/FX-MM850-ST, 2 km
856-19741	IE-MiniFiberLinX-II Module, TP-TX/FX-MM850-SC, 2 km
856-19732	IE-MiniFiberLinX-II Module, TP-TX/FX-MM1300-ST, 2 km
856-19733	IE-MiniFiberLinX-II Module, TP-TX/FX-MM1300-SC, 2 km
856-19734	IE-MiniFiberLinX-II Module, TP-TX/FX-SM1310/PLUS-ST, 30 km
856-19735	IE-MiniFiberLinX-II Module, TP-TX/FX-SM1310/PLUS-SC, 30 km
856-19736	IE-MiniFiberLinX-II Module, TP-TX/FX-SM1310/LONG-ST, 80 km
856-19737	IE-MiniFiberLinX-II Module, TP-TX/FX-SM1310/LONG-SC, 80 km

Single-Strand Fiber

856-19760	IE-MiniFiberLinX-II Module, TP-TX/SSFx-MM1310-SC (1310xmt/1550rcv), 2 km
856-19761	IE-MiniFiberLinX-II Module, TP-TX/SSFx-MM1550-SC (1550xmt/1310rcv), 2 km
856-19762	IE-MiniFiberLinX-II Module, TP-TX/SSFx-SM1310-SC (1310xmt/1550rcv), 20 km
856-19763	IE-MiniFiberLinX-II Module, TP-TX/SSFx-SM1550-SC (1550xmt/1310rcv), 20 km
856-19764	IE-MiniFiberLinX-II Module, TP-TX/SSFx-SM1310/PLUS-SC (1310xmt/1550rcv), 40 km
856-19765	IE-MiniFiberLinX-II Module, TP-TX/SSFx-SM1550/PLUS-SC (1550xmt/1310rcv), 40 km
856-19766	IE-MiniFiberLinX-II Module, TP-TX/SSFx-SM1310/LONG-SC (1310xmt/1550rcv), 60 km
856-19767	IE-MiniFiberLinX-II Module, TP-TX/SSFx-SM1550/LONG-SC (1550xmt/1310rcv), 60 km

CWDM version available,
Call IMC Networks for details





MiniMc, MiniMc SFP, and IE-PowerTray/18



The smallest, most reliable and most cost effective switching and Gigabit-only media converters in the industry.

Product Overview

Media conversion is the most cost-effective solution for extending the productive life of legacy wiring plants and equipment while allowing implementation of new technologies. Media conversion's greatest benefits are flexibility and cost savings.

Measuring less than 3.5 inches deep and 2 inches wide, the MiniMc is the industry's smallest media converter with both data connections on the same side of the unit, and at a fraction of the cost of other alternatives. Plug-and-play operation with a variety of model types and powering options make the MiniMc series easy and convenient to use.

MiniMc SFP includes:

- One SFP fiber port
- One 10/100 Base-TX twisted pair port that auto-senses the connected device's rate and duplex mode (Half-Duplex/Full-Duplex)

MiniMc includes:

- One 100 Mbps FDX fiber port
- One 10/100 Base-TX twisted pair port that auto-senses the connected device's rate and duplex mode (Half-Duplex/Full-Duplex)

Application Example

Connect up to 18 MiniMcS in an IE-PowerTray/18 and network with up to 18 remote locations using 1.5 rack units of space.

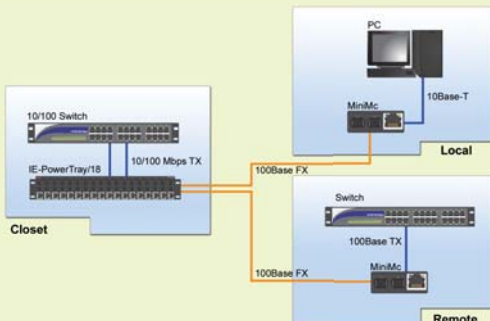

Features

Perfect for a variety of applications

- Low cost media converter
- Standalone converter includes country specific, high-reliability power adapter or use converter with USB-power cord (10/100 Mbps only)

Space saving alternative

- Standalone unit has small, rugged enclosure with compact, external power supply
- 18 connections in the 1.5U high IE-PowerTray/18 rackmountable enclosure
- Can be ordered without AC adapter for IE-PowerTray/18 installation

All versions include:

- Auto-Cross automatic selection between crossover or straight-through cable
- Status LEDs

Physical Specifications

Fiber Types Supported

- 50/125µm or 62.5/125µm multi-mode fiber
- 9/125µm single-mode fiber
- Available for single-strand fiber

Connectors:

RJ-45, ST, SC and SFP(only on MiniMc SFP version)

Regulatory Approvals:

FCC Class B, UL/cUL, CE, CSA

Operating Temperature:

+32° to +122°F (0° to +50°C)

Storage Temperature:

-13° to +158°F (-25° to +70°C)

Humidity:

5 to 95% (non-condensing)

Altitude:

0 to 10,000 ft.

Dimensions

0.83"H x 1.80"W x 3.35"D (2.11 x 4.57 x 8.51 cm)

Power Rating:

AC Wall adapter: 100/240 ±10% VAC input, 50/60 Hz 5V DC output at 10W, 2.0A

Shipping Weight:

0.7 lbs (0.3 kg)

Physical Specifications

IE-PowerTray/18

Regulatory Approvals:

FCC Class A, UL/cUL, CE, CSA

Operating Temperature:

-4° to +158°F (-20° to +70°C)

Storage Temperature:

-40° to +185°F (-40° to +85°C)

Humidity:

5 to 95% (non-condensing)

Altitude:

0 to 10,000 ft.

Dimensions

2.30"H x 16.97"W x 9.25"D (5.80 x 43.10 x 23.5 cm)

Power Rating:

AC input Load: 10-240V AC, 50/60Hz, 1.5A

Shipping Weight:

10 lbs (4.5 kg)

Ordering Information

MiniMc: TP-TX/SFP

855-10619 MiniMc, TP-TX/SFP (requires one IE-SFP/155 Module)

MiniMc: TP-TX/FX and TP-TX/SX

855-10620	MiniMc, TP-TX/FX-MM850-ST, 2 km
855-10621	MiniMc, TP-TX/FX-MM850-SC, 2 km
855-10622	MiniMc, TP-TX/FX-MM1300-ST, 5 km
855-10623	MiniMc, TP-TX/FX-MM1300-SC, 5 km
855-10624	MiniMc, TP-TX/FX-SM1310/PLUS-ST, 40 km
855-10625	MiniMc, TP-TX/FX-SM1310/PLUS-SC, 40 km
855-10626	MiniMc, TP-TX/FX-SM1310/LONG-ST, 80 km
855-10627	MiniMc, TP-TX/FX-SM1310/LONG-SC, 80 km
855-10641	MiniMc, TP-TX/FX-SM1550/LONG-SC, 80 km

Single-Strand Fiber

855-10650	MiniMc, TP-TX/SSFx-MM1300-SC (1300xmt/1550rcv), 2 km
855-10651	MiniMc, TP-TX/SSFx-MM1550-SC (1550xmt/1300rcv), 2 km
855-10652	MiniMc, TP-TX/SSFx-SM1310-SC (1310xmt/1550rcv), 20 km
855-10653	MiniMc, TP-TX/SSFx-SM1550-SC (1550xmt/1310rcv), 20 km
855-10654	MiniMc, TP-TX/SSFx-SM1310/PLUS-SC (1310xmt/1550rcv), 40 km
855-10655	MiniMc, TP-TX/SSFx-SM1550/PLUS-SC (1550xmt/1310rcv), 40 km
855-10656	MiniMc, TP-TX/SSFx-SM1310/LONG-SC (1310xmt/1550rcv), 60 km
855-10657	MiniMc, TP-TX/SSFx-SM1550/LONG-SC (1550xmt/1310rcv), 60 km

Available Accessories

806-39623	AC Power Adapter for MiniMc products (10 watt, 0°C to +50°C)
806-00322-00	Power Adapter Clip (USA)
806-00322-01	Power Adapter Clip (UK)
806-00322-02	Power Adapter Clip (Europe)
806-00322-03	Power Adapter Clip (Australia/New Zealand)
806-39628	36" USB Power Cable (for MiniMc only)
806-39629	12" USB Power Cable (for MiniMc only)
806-39105	DIN Rail Clip



IE-PowerTray Chassis (18 slots)

850-13086	IE-PowerTray/18-AC (1.5U high, rackmountable enclosure)
-----------	---

* Modular versions without AC adapter change the first Part Number to 854 (i.e. 855-10620 becomes 854-10620).

CWDM version available, Call IMC Networks for details



MiniMc-Gigabit, Giga-MiniMc

6-YEAR
Comprehensive
Warranty



The smallest, most reliable and most cost effective switching and Gigabit-only media converters in the industry.

Product Overview

Media conversion is the most cost-effective solution for extending the productive life of legacy wiring plants and equipment while allowing implementation of new technologies. Media conversion's greatest benefits are flexibility and cost savings.

Measuring less than 3.5 inches deep and 2 inches wide, the MiniMc is the industry's smallest media converter with both data connections on the same side of the unit, and at a fraction of the cost of other alternatives. Plug-and-play operation with a variety of model types and powering options make the MiniMc series easy and convenient to use.

MiniMc-Gigabit includes:

- One 1000Base-SX or 1000Base-LX fiber port
- One 1000Base-T twisted pair port

Giga-MiniMc includes:

- One 1000Base-SX or 1000Base-LX fiber port
- One 10/100/1000 Mbps twisted pair port that auto-senses the connected device's speed and duplex mode (Half-Duplex/Full-Duplex)

Features

Perfect for a variety of applications

- Low cost media converter
- Standalone converter includes country specific, high-reliability power adapter or use converter with USB-power cord (10/100 Mbps only)

Space saving alternative

- Standalone unit has small, rugged enclosure with compact, external power supply
- 18 connections in the 1.5U high IE-PowerTray/18 rackmountable enclosure
- Can be ordered without AC adapter for IE-PowerTray/18 installation

All versions include:

- Auto-Cross automatic selection between crossover or straight-through cable
- Status LEDs

Physical Specifications

Fiber Types Supported

- 50/125µm or 62.5/125µm multi-mode fiber
- 9/125µm single-mode fiber
- Available for single-strand fiber

Connectors:

RJ-45, ST, SC and SFP (only on MiniMc SFP version)

Regulatory Approvals:

FCC Class B, UL/cUL, CE, CSA

Operating Temperature:

+32° to +122°F (0° to +50°C)

Storage Temperature:

-13° to +158°F (-25° to +70°C)

Humidity:

5 to 95% (non-condensing)

Altitude:

0 to 10,000 ft.

Dimensions

0.83"H x 1.80"W x 3.35"D (2.11 x 4.57 x 8.51 cm)

Power Rating:

AC Wall adapter: 100/240 ±10% VAC input, 50/60 Hz 5V DC output at 10W, 2.0A

Shipping Weight:

0.7 lbs (0.3 kg)

Available Accessories

806-39623	AC Power Adapter for MiniMc products (10 watt, 0°C to +50°C)
806-00322-00	Power Adapter Clip (USA)
806-00322-01	Power Adapter Clip (UK)
806-00322-02	Power Adapter Clip (Europe)
806-00322-03	Power Adapter Clip (Australia/New Zealand)
806-39628	36" USB Power Cable (for MiniMc only)
806-39629	12" USB Power Cable (for MiniMc only)
806-39105	DIN Rail Clip

Ordering Information

MiniMc-Gigabit: TX/SX and TX/LX **

855-10730	MiniMc-Gigabit, TX/SX-MM850-SC, 550 m
855-10731	MiniMc-Gigabit, TX/LX-SM1310-SC, 15 km
855-10732	MiniMc-Gigabit, TX/LX-SM1310/PLUS-SC, 40 km
855-10733	MiniMc-Gigabit, TX/LX-SM1550/LONG-SC, 80 km
Single-Strand Fiber	
855-10734	MiniMc-Gigabit, TX/SSLX-SM1310-SC (1310xmt/1550rcv), 15 km
855-10735	MiniMc-Gigabit, TX/SSLX-SM1550-SC (1550xmt/1310rcv), 15 km
855-10742	MiniMc-Gigabit, TX/SSBX-SM1310-SC (1310xmt/1490rcv), 15 km
855-10743	MiniMc-Gigabit, TX/SSBX-SM1490-SC (1490xmt/1310rcv), 15 km
855-10736	MiniMc-Gigabit, TX/SSLX-SM1310/PLUS-SC (1310xmt/1550rcv), 40 km
855-10737	MiniMc-Gigabit, TX/SSLX-SM1550/PLUS-SC (1550xmt/1310rcv), 40 km
855-10744	MiniMc-Gigabit, TX/SSBX-SM1310/PLUS-SC (1310xmt/1490rcv), 30 km
855-10745	MiniMc-Gigabit, TX/SSBX-SM1490/PLUS-SC (1490xmt/1310rcv), 30 km
855-10738	MiniMc-Gigabit, TX/SSLX-SM1490/LONG-SC (1490xmt/1550rcv), 70 km
855-10739	MiniMc-Gigabit, TX/SSLX-SM1550/LONG-SC (1550xmt/1490rcv), 70 km
855-10740	MiniMc-Gigabit, TX/SSLX-SM1490/XLONG-SC (1490xmt/1550rcv), 70 km
855-10741	MiniMc-Gigabit, TX/SSLX-SM1550/XLONG-SC (1550xmt/1490rcv), 70 km

Giga-MiniMc: TX/SX and TX/LX *

856-10730	Giga-MiniMc, TX/SX-MM850-SC, 550 m
856-10731	Giga-MiniMc, TX/LX-SM1310-SC, 15 km
856-10732	Giga-MiniMc, TX/LX-SM1310/PLUS-SC, 40 km
856-10733	Giga-MiniMc, TX/LX-SM1550/LONG-SC, 80 km
856-10729	Giga-MiniMc, TX/LX-SM1550/XLONG-SC, 100 km
Single-Strand Fiber	
856-10734	Giga-MiniMc, TX/SSLX-SM1310-SC (1310xmt/1550rcv), 15 km
856-10735	Giga-MiniMc, TX/SSLX-SM1550-SC (1550xmt/1310rcv), 15 km
856-10742	Giga-MiniMc, TX/SSBX-SM1310-SC (1310xmt/1490rcv), 15 km
856-10743	Giga-MiniMc, TX/SSBX-SM1490-SC (1490xmt/1310rcv), 15 km
856-10736	Giga-MiniMc, TX/SSLX-SM1310/PLUS-SC (1310xmt/1550rcv), 40 km
856-10737	Giga-MiniMc, TX/SSLX-SM1550/PLUS-SC (1550xmt/1310rcv), 40 km
856-10744	Giga-MiniMc, TX/SSBX-SM1310/PLUS-SC (1310xmt/1490rcv), 30 km
856-10745	Giga-MiniMc, TX/SSBX-SM1490/PLUS-SC (1490xmt/1310rcv), 30 km
856-10738	Giga-MiniMc, TX/SSLX-SM1490/LONG-SC (1490xmt/1550rcv), 70 km
856-10739	Giga-MiniMc, TX/SSLX-SM1550/LONG-SC (1550xmt/1490rcv), 70 km
856-10740	Giga-MiniMc, TX/SSLX-SM1490/XLONG-SC (1490xmt/1550rcv), 70 km
856-10741	Giga-MiniMc, TX/SSLX-SM1550/XLONG-SC (1550xmt/1490rcv), 70 km

* Giga-MiniMc Modular versions without AC adapter change the first Part Number to 854 (i.e., 855-10620 becomes 854-10620).

** MiniMc-Gigabit Modular version without AC adapter, (Call IMC for Details).

Application Example

Connect up to 18 MiniMc's in an IE-PowerTray/18 and network with up to 18 remote locations using 1.5 rack units of space.

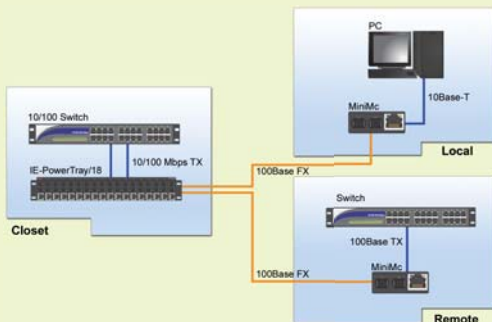

CWDM version available,
Call IMC Networks for details

IE-MiniMc & IE-Giga-MiniMc



The fast-growing MiniMc series includes an Industrial Ethernet model, allowing operation in extreme temperatures, with additional power and mounting options.

Product Overview

Equipped with all the features of the original — copper-to-fiber conversion, plug-and-play operation, miniature size and multiple power options — the IE-MiniMc also supports the IEEE 802.3af Power Over Ethernet (PoE) standard to function as a powered device.

All versions include:

- Extended operating temperature of -35 to +70° C
- Auto-Cross automatic selection between crossover or straight-through cable
- Status LEDs
- DIN clips, allowing installation on a DIN rail

IE-MiniMc includes:

- One 100 Mbps Full-Duplex fiber port
- One 10/100 Base-TX twisted-pair port that auto-senses the connected device's rate and duplex mode (Half-Duplex/Full-Duplex)
- Twisted pair port also functions as a Powered Device port, supporting Power Over Ethernet (PoE)

IE-Giga-MiniMc includes:

- One 1000Base-SX or 1000Base-LX fiber port
- One 10/100/1000 Mbps twisted-pair port that auto-senses the connected device's speed and duplex mode (Half-Duplex/Full-Duplex)

Application Examples

DIN Rail clips are included with the IE MiniMc, allowing installation on a DIN rail. When installing multiple IE-MiniMc units on a DIN rail, one DC input source can cascade from one DC block to the next, until reaching the maximum electrical current available.

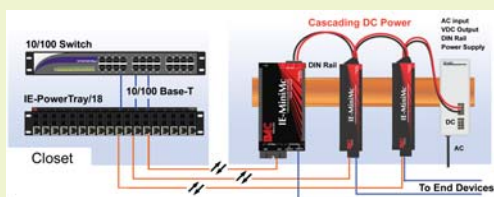

Features

Most cost-effective fiber converter available today

- Low cost, high flexibility — connects 10/100 Mbps copper to 100 Mbps fiber
- Install for use in extreme temperatures

Multiple powering options for a variety of applications

- Includes 4-terminal DC power block
- Includes country-specific, AC power adapter (0° to +50°C)
- IE-MiniMc supports IEEE 802.3af Power over Ethernet standard; draws power from power sourcing equipment (10/100 version only)

Space saving alternative

- Standalone unit has small, rugged enclosure with compact, external power supply
- 18 connections in the 1.5U high IE-PowerTray/18 rackmountable enclosure
- Can be ordered without AC adapter for IE-PowerTray/18 installation
- Mounts on DIN rail

Physical Specifications

Fiber Types Supported

- 50/125µm or 62.5/125µm multi-mode fiber
- 9/125µm single-mode fiber
- Available for single-strand fiber

Connectors:

RJ-45, ST and SC

Regulatory Approvals:

FCC Class B, UL/cUL, CE, CSA, CB

Operating Temperature:

+31° to +158°F (-35° to +70°C) Without AC Adapter
+32° to +122°F (0° to +50°C) With AC Adapter

Storage Temperature:

-31° to +167°F (-35° to +75°C)

Humidity:

5 to 95% (non-condensing)

Altitude:

0 to 10,000 ft.

Dimensions

0.83"H x 1.80"W x 3.35"D (2.11 x 4.57 x 8.51 cm)

Power Rating:

AC Wall adapter: 100/240 ±10% VAC input, 50/60 Hz
5V DC output at 10W, 2.0A
7-50V DC, 1A-0.1A

Shipping Weight:

0.7 lbs (0.3 kg)

Available Accessories

806-39623	AC Power Adapter for MiniMc products (10 watt, 0°C to +50°C)
806-00322-00	Power Adapter Clip (USA)
806-00322-01	Power Adapter Clip (UK)
806-00322-02	Power Adapter Clip (Europe)
806-00322-03	Power Adapter Clip (Australia/New Zealand)
806-39628	36" USB Power Cable (for MiniMc only)
806-39629	12" USB Power Cable (for MiniMc only)
806-39105	DIN Rail Clip

Ordering Information

IE-MiniMc: TP-TX/FX

855-19720	IE-MiniMc, TP-TX/FX-MM850-ST, 2 km
855-19721	IE-MiniMc, TP-TX/FX-MM850-SC, 2 km
855-19722	IE-MiniMc, TP-TX/FX-MM1300-ST, 2 km
855-19723	IE-MiniMc, TP-TX/FX-MM1300-SC, 2 km
855-19724	IE-MiniMc, TP-TX/FX-SM1310/PLUS-ST, 30 km
855-19725	IE-MiniMc, TP-TX/FX-SM1310/PLUS-SC, 30 km
855-19726	IE-MiniMc, TP-TX/FX-SM1310/LONG-ST, 80 km
855-19727	IE-MiniMc, TP-TX/FX-SM1310/LONG-SC, 80 km

Single-Strand Fiber

855-19750	IE-MiniMc, TP-TX/SSFx-MM1310-SC (1310xmt/1550rcv), 2 km
855-19751	IE-MiniMc, TP-TX/SSFx-MM1550-SC (1550xmt/1310rcv), 2 km
855-19752	IE-MiniMc, TP-TX/SSFx-SM1310-SC (1310xmt/1550rcv), 20 km
855-19753	IE-MiniMc, TP-TX/SSFx-SM1550-SC (1550xmt/1310rcv), 20 km
855-19754	IE-MiniMc, TP-TX/SSFx-SM1310/PLUS-SC (1310xmt/1550rcv), 40 km
855-19755	IE-MiniMc, TP-TX/SSFx-SM1550/PLUS-SC (1550xmt/1310rcv), 40 km
855-19756	IE-MiniMc, TP-TX/SSFx-SM1310/LONG-SC (1310xmt/1550rcv), 60 km
855-19757	IE-MiniMc, TP-TX/SSFx-SM1550/LONG-SC (1550xmt/1310rcv), 60 km

IE-Giga-MiniMc: TX/LX or TX/SX

856-18830	IE-Giga-MiniMc, TX/FX-MM850-SC, 550 m
856-18831	IE-Giga-MiniMc, TX/LX-SM1310-SC, 15 km
856-18832	IE-Giga-MiniMc, TX/LX-SM1310/PLUS-SC, 30 km
856-18833	IE-Giga-MiniMc, TX/LX-SM1550/LONG-SC, 80 km
856-18834	IE-Giga-MiniMc, TX/LX-SM1550/XLONG-SC, 100 km

Single Strand Fiber

856-18835	IE-Giga-MiniMc, TX/SSLX-SM1310-SC (1310xmt/1550rcv), 15 km
856-18836	IE-Giga-MiniMc, TX/SSLX-SM1550-SC (1550xmt/1310rcv), 15 km
856-18825	IE-Giga-MiniMc, TX/SSBX-SM1310-SC (1310xmt/1490rcv), 10 km
856-18826	IE-Giga-MiniMc, TX/SSBX-SM1490-SC (1490xmt/1310rcv), 10 km
856-18837	IE-Giga-MiniMc, TX/SSLX-SM1310/PLUS-SC (1310xmt/1550rcv), 40 km
856-18838	IE-Giga-MiniMc, TX/SSLX-SM1550/PLUS-SC (1550xmt/1310rcv), 40 km
856-18827	IE-Giga-MiniMc, TX/SSBX-SM1310/PLUS-SC (1310xmt/1490rcv), 30 km
856-18828	IE-Giga-MiniMc, TX/SSBX-SM1490/PLUS-SC (1490xmt/1310rcv), 30 km
856-18839	IE-Giga-MiniMc, TX/SSLX-SM1490/LONG-SC (1490xmt/1550rcv), 60 km
856-18840	IE-Giga-MiniMc, TX/SSLX-SM1550/LONG-SC (1550xmt/1490rcv), 60 km
856-18841	IE-Giga-MiniMc, TX/SSLX-SM1490/XLONG-SC (1490xmt/1550rcv), 70 km
856-18842	IE-Giga-MiniMc, TX/SSLX-SM1550/XLONG-SC (1550xmt/1490rcv), 70 km

Use with Chassis Platform IE-PowerTray/18, See Page 8

* Modular versions without AC adapter change the first Part Number to 854 (i.e. 855-10620 becomes 854-10620).

CWDM version available,
Call IMC Networks for details



10/100 Mbps Auto Negotiating Copper (TX), 100 Mbps Fiber (FX) Ethernet

PD-Switch



The PD-Switch combines flexible copper and fiber interface options with port and packet-based traffic prioritization while extending network range by utilizing Power over Ethernet (PoE) technology

Product Overview

The (PoE) PD-Switch is a full-featured, 5-port MAC layer 10/100Base-T switch that extends the range of Ethernet networks, and increases port density, while being powered via IEEE 802.3af compliant PoE through its "PD-port" (eliminating the need to run a separate power line for the device). Ethernet cabling typically runs only 100 meters; the PD-Switch, extends the outer range of an ethernet network by an additional 100 meters.

With multiple port configurations, the PD-Switch provides a variety of port options while increasing port density. PD-Switches come equipped with one "PD" RJ-45 port and either:

- Four 10/100Base-T RJ-45 data ports
- Three 10/100Base-T RJ-45 data ports and one SFP data port (rate depends on SFP)
- Two 10/100Base-T RJ-45 data ports and one 100Base-FX fiber data port

Application Example

The PD-Switch has been connected to a central (PoE) PSE-Switch, extending the range of the network and increasing port density by using a combination of RJ-45 ports and fiber ports.

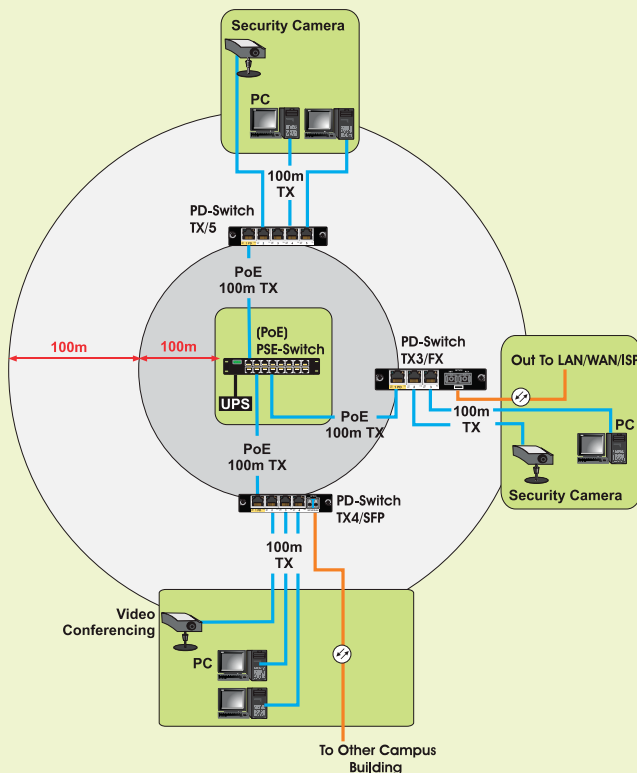

Features

Multi-port switch powered by the IEEE 802.3af Power Over Ethernet Standard

- PD accepts power from any network device providing PoE
- Multiple ports increase network port density

Meets a multitude of installation requirements

- SFP and fiber port configurations (optional) for different network environments
- All RJ-45 ports feature Auto-Cross and Auto Negotiation
- Port for High Priority traffic
- Available with ST or SC fiber connectors
- Optional single-strand fiber model

Full-Featured Switch

- Broadcast Storm Protection helps control excessive broadcast traffic
- DiffServ on all ports provides Quality of Service prioritization
- Far End Fault provides notification of Link Loss on all fiber ports
- Supports 1916 byte Packet Size

Physical Specifications

Fiber Types Supported

- 50/125µm or 62.5/125µm multi-mode fiber
- 9/125µm single-mode fiber
- Available for single-strand fiber and SFP

Connectors:

RJ-45, ST, SC and SFP

Regulatory Approvals:

FCC Class B, CE

Operating Temperature:

+32° to +122°F (0° to +50°C)

Storage Temperature:

-13° to +158°F (-25° to +70°C)

Humidity:

5 to 95% (non-condensing)

Altitude:

0 to 10,000 ft.

Dimensions

1.55"H x 4.75"L x 7.31"D (3.94 x 12.07 x 18.57 cm)

Power Rating:

36V DC-50V DC, 56mA-40mA

Shipping Weight:

1.8 lbs (0.82 kg)

Ordering Information

852-16440	PD-Switch, TX/5, 100 m
852-16441	PD-Switch, TX/4 + SFP, Various
852-16442	PD-Switch, TX/3 + FX-MM850-ST, 2 km
852-16443	PD-Switch, TX/3 + FX-MM850-SC, 2 km
852-16444	PD-Switch, TX/3 + FX-MM1300-ST, 5 km
852-16445	PD-Switch, TX/3 + FX-MM1300-SC, 5 km
852-16446	PD-Switch, TX/3 + SSFX-SM1310/PLUS-SC, 40 km
852-16447	PD-Switch, TX/3 + FX-SM1310/PLUS-SC, 40 km
852-16448	PD-Switch, TX/3 + FX-SM1310/LONG-ST, 80 km
852-16449	PD-Switch, TX/3 + FX-SM1310/LONG-SC, 80 km
852-16450	PD-Switch, TX/3 + FX-SM1550/LONG-SC, 80 km

Single-Strand Fiber

852-16470	PD-Switch, TX/3 + SSFX-SM1310-SC (1310xmt/1550rcv), 20 km
852-16471	PD-Switch, TX/3 + SSFX-SM1550-SC (1550xmt/1310rcv), 20 km
852-16472	PD-Switch, TX/3 + SSFX-SM1310/PLUS-SC (1310xmt/1550rcv), 40 km
852-16473	PD-Switch, TX/3 + SSFX-SM1550/PLUS-SC (1550xmt/1310rcv), 40 km
852-16474	PD-Switch, TX/3 + SSFX-SM1310/LONG-SC (1310xmt/1550rcv), 60 km
852-16475	PD-Switch, TX/3 + SSFX-SM1550/LONG-SC (1550xmt/1310rcv), 60 km





McBasic Series



With its small yet rugged design, internal AC power supply and troubleshooting features, the McBasic is the best standalone media converter in the industry.

Product Overview

When simple, individual, copper-to-fiber or copper-to-coax conversions are required, along with advanced troubleshooting features, installing McBasic Series standalone media converters is the perfect, cost-effective solution. The McBasic's small, table-top design and durability make it perfect for installation anywhere space is limited.

The McBasic helps make isolating fiber breaks easier with such features as LinkLoss, FiberAlert, Transparency and Link Fault Detection. The McBasic also features either AutoCross or switch-selectable crossover/pass-through on twisted pair connections, with switch-selectable termination on BNC ports. The McBasic-Gigabit offers all the benefits of the McBasic in addition to Link Fault Pass-Through, but with gigabit speeds.

McBasic 10 Mbps Converters:

- Convert 10 Mbps twisted pair to 10 Mbps fiber.
- Convert 10 Mbps twisted pair to 10 Mbps thin coax.

McBasic 100 Mbps Converters:

- Convert 100 Mbps twisted pair to 100 Mbps fiber.

McBasic 10/100, Auto Sensing Dual-Speed Converters:

- Convert 10 Mbps twisted pair to 10 Mbps fiber OR convert 100 Mbps twisted pair to 100 Mbps fiber.

McBasic-Gigabit 1000 Mbps Converters:

- Convert 1000 Mbps twisted pair to 1000 Mbps fiber.

Application Example

The diagram illustrates the wide variety of media converters available from IMC Networks including the 10/100 McBasic.

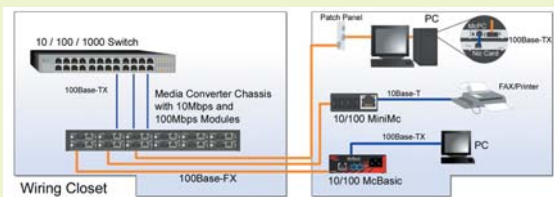

Features

Perfect for a variety of applications

- Small, rugged design offers many advanced features

Meets a multitude of installation requirements

- McBasic: available in 10 Mbps, 100 Mbps and auto-sensing 10/100 Mbps versions
- McBasic-Gigabit: available in 1000 Mbps version

Converts 10 Mbps twisted pair to fiber today, and 100 Mbps twisted pair to fiber tomorrow

- McBasic 10/100 provides transparent end-to-end 10/100 Auto Negotiation for easy upgrade; no user intervention or visits to remote locations required
- McBasic Gigabit also features LFTP

Physical Specifications

Fiber Types Supported

- 50/125µm or 62.5/125µm multi-mode fiber
- 9/125µm single-mode fiber
- Available for single-strand fiber

Connectors:

RJ-45, ST, SC (McBasic-Gigabit has SC fiber only)

Regulatory Approvals McBasic:

McBasic: FCC Class B, CE, UL/cUL, CSA

McBasic-Gigabit: FCC Class A, CE, UL/cUL, CSA

Operating Temperature:

+32° to +122°F (0° to +50°C)

Storage Temperature:

0° to +160°F (-20° to +70°C)

Humidity:

5 to 95% (non-condensing)

Altitude:

0 to 10,000 ft.

Dimensions

1.64"H x 4.75"W x 4.95"D (4.2 x 12.1 x 12.6 cm)

McBasic Gigabit Dimensions:

1.64"H x 4.75"W x 7.3"D (4.2 x 12.1 x 18.6 cm)

Power Rating:

100-240V AC, 50/60Hz, 1.0A

Shipping Weight:

1.7 lbs (0.77 kg) McBasic Gigabit Only

1.3 lbs (0.58 kg) All others

Ordering Information

McBasic TP/FO and TP/BNC

855-10230	McBasic, TP/FO-MM850-ST, 2 km
855-10231	McBasic, TP/FO-MM850-SC, 2 km
855-10232	McBasic, TP/FO-MM1300-ST, 2 km
855-10233	McBasic, TP/FO-MM1300-SC, 2 km
855-10234	McBasic, TP/FO-SM1310/PLUS-ST, 40 km
855-10235	McBasic, TP/FO-SM1310/PLUS-SC, 40 km
855-10237	McBasic, TP/FO-SM1310/LONG-ST, 70 km
855-10238	McBasic, TP/FO-SM1310/LONG-SC, 70 km
855-10240	McBasic, TP/FO-SM1550/LONG-SC, 80 km

McBasic TX/FX

855-10929	McBasic, TX/FX-MM850-ST, 2 km
855-10930	McBasic, TX/FX-MM850-SC, 2 km
855-10927	McBasic, TX/FX-MM1300-ST, 2 km
855-10928	McBasic, TX/FX-MM1300-SC, 2 km
855-10931	McBasic, TX/FX-SM1310/PLUS-ST, 40 km
855-10932	McBasic, TX/FX-SM1310/PLUS-SC, 40 km
855-10933	McBasic, TX/FX-SM1310/LONG-ST, 80 km
855-10934	McBasic, TX/FX-SM1310/LONG-SC, 80 km
855-10937	McBasic, TX/FX-SM1550/LONG-SC, 80 km

Single-Strand Fiber

855-10949	McBasic, TX/SSFx-MM1310-SC (1310xmt/1550rcv), 2 km
855-10950	McBasic, TX/SSFx-MM1550-SC (1550xmt/1310rcv), 2 km
855-10951	McBasic, TX/SSFx-SM1310-SC (1310xmt/1550rcv), 20 km
855-10952	McBasic, TX/SSFx-SM1550-SC (1550xmt/1310rcv), 20 km
855-10953	McBasic, TX/SSFx-SM1310/PLUS-SC (1310xmt/1550rcv), 40 km
855-10954	McBasic, TX/SSFx-SM1550/PLUS-SC (1550xmt/1310rcv), 40 km
855-10955	McBasic, TX/SSFx-SM1310/LONG-SC (1310xmt/1550rcv), 60 km
855-10957	McBasic, TX/SSFx-SM1550/LONG-SC (1550xmt/1310rcv), 60 km

McBasic 10/100

855-10260	McBasic, 10/100-MM850-ST, 2 km
855-10261	McBasic, 10/100-MM850-SC, 2 km
855-10262	McBasic, 10/100-MM1300-ST, 2 km
855-10263	McBasic, 10/100-MM1300-SC, 2 km
855-10267	McBasic, 10/100-SM1310/PLUS-ST, 40 km
855-10268	McBasic, 10/100-SM1310/PLUS-SC, 40 km
855-10269	McBasic, 10/100-SM1310/LONG-ST, 80 km
855-10270	McBasic, 10/100-SM1310/LONG-SC, 80 km
855-10274	McBasic, 10/100-SM1550/LONG-SC, 80 km

McBasic-Gigabit Ethernet (LFPT)

855-11913	McBasic-Gigabit, TX/SX-MM850-SC, 550 m
855-11914	McBasic-Gigabit, TX/LX-SM1310-SC, 15 km
855-11915	McBasic-Gigabit, TX/LX-SM1310/PLUS-SC, 40 km
855-11917	McBasic-Gigabit, TX/LX-SM1550/LONG-SC, 80 km
855-11918	McBasic-Gigabit, TX/LX-SM1550/XLONG-SC, 100 km

Single-Strand Fiber

855-11844	McBasic-Gigabit, TX/SSLX-SM1310-SC (1310xmt/1550rcv), 15 km
855-11845	McBasic-Gigabit, TX/SSLX-SM1550-SC (1550xmt/1310rcv), 15 km
855-11824	McBasic-Gigabit, TX/SSBX-SM1310-SC (1310xmt/1490rcv), 10 km
855-11825	McBasic-Gigabit, TX/SSBX-SM1490-SC (1490xmt/1310rcv), 10 km
855-11846	McBasic-Gigabit, TX/SSLX-SM1310/PLUS-SC (1310xmt/1550rcv), 40 km
855-11847	McBasic-Gigabit, TX/SSLX-SM1550/PLUS-SC (1550xmt/1310rcv), 40 km
855-11826	McBasic-Gigabit, TX/SSBX-SM1310/PLUS-SC (1310xmt/1490rcv), 30 km
855-11827	McBasic-Gigabit, TX/SSBX-SM1450/PLUS-SC (1490xmt/1310rcv), 30 km
855-11850	McBasic-Gigabit, TX/SSLX-SM1490/LONG-SC (1490xmt/1550rcv), 60 km
855-11851	McBasic-Gigabit, TX/SSLX-SM1550/LONG-SC (1550xmt/1490rcv), 60 km
855-11852	McBasic-Gigabit, TX/SSLX-SM1490/XLONG-SC (1490xmt/1550rcv), 70 km
855-11853	McBasic-Gigabit, TX/SSLX-SM1550/XLONG-SC (1550xmt/1490rcv), 70 km

Accessories See page 34



100 Mbps Power Over Ethernet Sourcing Standalone Media Converters

PSE-McBasic



Supporting the IEEE 802.3af PoE standard, the standalone PSE-McBasic media converter offers unparalleled installation flexibility and cost-savings.

Product Overview

Equipped with all the features that have made the McBasic series one of IMC Networks' most popular brands — copper-to-fiber conversion, troubleshooting capability, a small yet rugged design, and an internal AC power supply — the PSE-McBasic uses the IEEE 802.3af Power over Ethernet (PoE) standard to create the ideal solution for installing devices such as IP security cameras and Wi-Fi access points at remote locations miles away from the central office. The PSE-McBasic series performs media conversion while providing power to the end-device at the remote site.

Power Over Ethernet technology allows the PSE-McBasic to be the Power Source Equipment (PSE) by distributing an electrical current across existing twisted pair data cabling. LEDs indicate the amount of power being supplied to the "Powered Device" (PD) as well as if the PSE-McBasic is over temperature or over current or has an open circuit.

Features

- 100Base-TX twisted pair
- 100Base-FX or SX fiber
- IEEE 802.3af compliant
- Includes fixed, internal AC power
- Switch for manual configuration
- Small, rugged design
- Supports Half and Full-Duplex operation
- Includes diagnostic LEDs

Physical Specifications

Fiber Types Supported

- 50/125µm or 62.5/125µm multi-mode fiber
- 9/125µm single-mode fiber
- Available for single-strand fiber

Connectors:

RJ-45, ST and SC

Regulatory Approvals:

FCC Class B, CE, UL/cUL, CSA

Operating Temperature:

+32° to +122°F (0° to +50°C)

Storage Temperature:

-13° to +158°F (-25° to +70°C)

Humidity:

5 to 95% (non-condensing)

Altitude:

0 to 10,000 ft.

Dimensions

1.45"H x 4.73"W x 7.30"D (3.68 x 12.01 x 18.54 cm)

Power Rating:

100-240V AC, 50/60Hz, 1A

Shipping Weight:

1.8 lbs (0.82 kg)

Ordering Information

PSE-McBasic: TX/FX

855-16929	PSE-McBasic, TX/FX-MM850-ST, 2 km
855-16930	PSE-McBasic, TX/FX-MM850-SC, 2 km
855-16927	PSE-McBasic, TX/FX-MM1300-ST, 5 km
855-16928	PSE-McBasic, TX/FX-MM1300-SC, 5 km
855-16931	PSE-McBasic, TX/FX-SM1310/PLUS-ST, 40 km
855-16932	PSE-McBasic, TX/FX-SM1310/PLUS-SC, 40 km
855-16933	PSE-McBasic, TX/FX-SM1310/LONG-ST, 80 km
855-16934	PSE-McBasic, TX/FX-SM1310/LONG-SC, 80 km
855-16935	PSE-McBasic, TX/FX-SM1550/LONG-SC, 80 km

Single-Strand Fiber

855-16951	PSE-McBasic, TX/SSFX-SM1310-SC (1310xmt/1550rcv), 20 km
855-16952	PSE-McBasic, TX/SSFX-SM1550-SC (1550xmt/1310rcv), 20 km
855-16953	PSE-McBasic, TX/SSFX-SM1310/PLUS-SC (1310xmt/1550rcv), 40 km
855-16954	PSE-McBasic, TX/SSFX-SM1550/PLUS-SC (1550xmt/1310rcv), 40 km
855-16955	PSE-McBasic, TX/SSFX-SM1310/LONG-SC (1310xmt/1550rcv), 60 km
855-16957	PSE-McBasic, TX/SSFX-SM1550/LONG-SC (1550xmt/1310rcv), 60 km

Application Example

By combining media conversion and PoE sourcing capabilities, PSE-McBasic can easily power remote network devices such as IP cameras and WiFi access points.

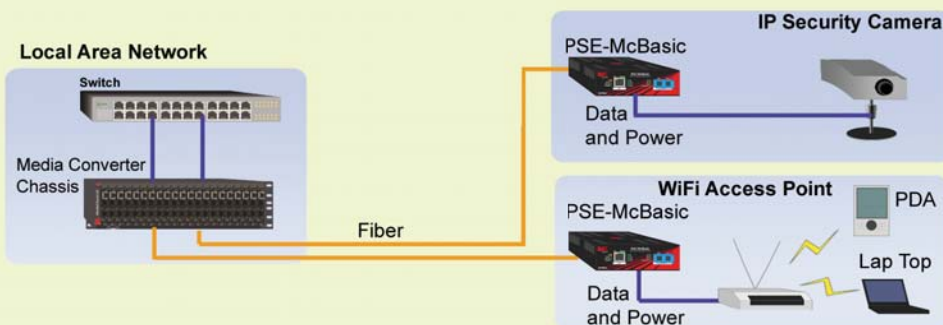



AccessConverter



Terminate fiber and connect multiple Ethernet devices — PCs, webcams, printers — at a remote location with the AccessConverter.

Product Overview

The AccessConverter is a multi-port media converter, aggregating three 10/100 Ethernet twisted pair ports into a single 100Base-FX uplink. While typical media converters perform a conversion between one twisted pair interface and one fiber optic interface, the AccessConverter has three 10/100 ports to significantly increase the application flexibility while reducing the cost per conversion.

The AccessConverter is an ideal solution for LAN workgroups and Fiber-to-the-Premises applications, connecting and aggregating multiple devices — such as PCs, servers, printers, and VoIP phones — into a fiber optic cabling infrastructure. Providing plug-and-play operation, the AccessConverter/3 features 10/100 Auto Negotiation and AutoCross on the twisted pair ports. The 100Base-FX uplink port supports ST and SC connectors for multi-mode, single-mode and single-strand fiber types, providing fiber connectivity from 2 km up to 80 km distances. Every unit ships with a country-specific power cord.

Features

Most cost-effective fiber converter available today

- Low cost, high flexibility— same small unit performs media conversion and switching functions
- Offers three downlink connections

Perfect for a variety of applications

- Device includes high-reliability power adapter with country-specific clip
- Uplink available on rear or front of unit
- Compact size allows for flexible installation configurations

Space saving alternative

- Device has small, rugged enclosure with compact external power supply
- Table-top or wall-mount installation

Physical Specifications

Fiber Types Supported

- 50/125µm or 62.5/125µm multi-mode fiber
- 9/125µm single-mode fiber
- Available for single-strand fiber

Connectors:

RJ-45, ST and SC

Regulatory Approvals:

FCC Class B, CE, UL/cUL, CSA

Operating Temperature:

+32° to +122°F (0° to +50°C)

Storage Temperature:

-13° to +18°F (-25° to +70°C)

Humidity:

5 to 95% (non-condensing)

Altitude:

0 to 10,000 ft.

Dimensions

0.92"H x 3.50"W x 4.38"D (2.34 x 8.89 x 11.13 cm)

Power Rating:

AC Wall adapter: 100/240 ±10% VAC input, 50/60 Hz 5V DC output at 10W, 2.0A

Shipping Weight:

1.1 lbs (0.50 kg)

Ordering Information

AccessConverter

852-10140	AccessConverter, TX/3 + TX, 100 m
852-10150	AccessConverter, TX/3 + FX-MM850-ST, 2 km
852-10151	AccessConverter, TX/3 + FX-MM850-SC, 2 km
852-10141	AccessConverter, TX/3 + FX-MM1300-ST, 5 km
852-10142	AccessConverter, TX/3 + FX-MM1300-SC, 5 km
852-10141-MT	AccessConverter, TX/3 + FX-MM1300-MT, 2 km
852-10143	AccessConverter, TX/3 + FX-SM1310/PLUS-ST, 40 km
852-10144	AccessConverter, TX/3 + FX-SM1310/PLUS-SC, 40 km
852-10145	AccessConverter, TX/3 + FX-SM1310/LONG-ST, 80 km
852-10146	AccessConverter, TX/3 + FX-SM1310/LONG-SC, 80 km
852-10147	AccessConverter, TX/3 + FX-SM1550/LONG-SC, 80 km

Single-Strand Fiber

852-10153	AccessConverter, TX/3 + SSFX-SM1310-SC (1310xmt/1550rcv), 20 km
852-10154	AccessConverter, TX/3 + SSFX-SM1550-SC (1550xmt/1310rcv), 20 km
852-10155	AccessConverter, TX/3 + SSFX-SM1310/PLUS-SC (1310xmt/1550rcv), 40 km
852-10156	AccessConverter, TX/3 + SSFX-SM1550/PLUS-SC (1550xmt/1310rcv), 40 km
852-10157	AccessConverter, TX/3 + SSFX-SM1310/LONG-SC (1310xmt/1550rcv), 60 km
852-10158	AccessConverter, TX/3 + SSFX-SM1550/LONG-SC (1550xmt/1310rcv), 60 km

Application Example

Provide media conversion capabilities for multiple network devices.

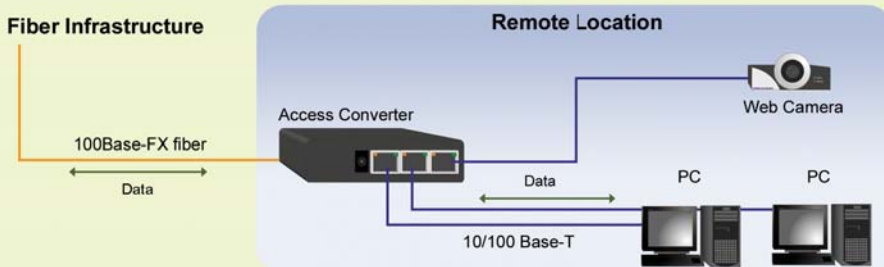



10, 100, Switching 10/100 Mbps and 1000 Mbps Ethernet Modular Media Converters

Mc Modules for MediaConverter Series (McPIM, McLIM, McGigabit)

6-YEAR
Comprehensive
Warranty



A cost-effective solution for extending the life of legacy equipment and bringing fiber-to-the-desktop.

Product Overview

When copper-to-fiber, copper-to-coax or fiber-to-fiber conversions are required for network growth, the MediaConverter Module Series is the perfect solution.

IMC Networks' MediaConverter Module Series enables easy and cost-effective connection of one type of media to other dissimilar media or networking products. This series extends the functionality and production life of both legacy cabling infrastructure and networking equipment when adding fiber to a network.

The MediaConverter Module Series includes:

McPIM:

- One 10 Mbps twisted pair port with an RJ-45 connector
- One 10 Mbps fiber port with ST, SC or MT-RJ connectors

McLIM:

- One 100 Mbps twisted pair port with an RJ-45 connector
- One 100 Mbps fiber port with ST, SC or MT-RJ connectors

Switching McLIM TP-TX/FX:

- One 10/100 Mbps twisted pair port with an RJ-45 connector
- One 100 Mbps fiber port with ST or SC connectors
- Plug-and-play operation

McGigabit:

- One 1000 Mbps twisted pair port with an RJ-45 connector
- One 1000 Mbps fiber port with SC connectors
- Plug-and-play operation

Application Example

Install modules in any MediaConverter chassis. If the number of required conversions is high but rackmount space is limited, choose the 1U high, 12-slot chassis.

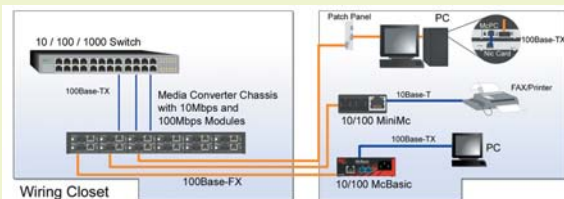

Features

Modules meet a variety of installation requirements

- Supports Ethernet, Fast Ethernet, and Gigabit Ethernet, and up to OC-3 for mode converters
- Supports very long fiber distances

A variety of chassis options

- Table-top or rackmountable
- 1, 4, 8 and 12-slot chassis
- 12-slot chassis is only 1U high
- AC power

Maximizes network uptime

- Modular, hot-swappable architecture reduces operational costs associated with product installation, upgrades and maintenance

Physical Specifications

Fiber Types Supported

- 50/125µm or 62.5/125µm multi-mode fiber
- 9/125µm single-mode fiber
- Available for single-strand fiber

Connectors:

RJ-45, ST and SC

Regulatory Approvals:

McPIM TP/FO: FCC Class A, CE

McLIM TX/FX: FCC Class B, CE

McGigabit: FCC Class B, CE

Operating Temperature:

+32° to +122°F (0° to +50°C)

Storage Temperature:

-13° to +158°F (-25° to +70°C)

Humidity:

5 to 95% (non-condensing)

Altitude:

0 to 10,000 ft.

Shipping Weight:

0.7 lbs (0.3 kg)

Dimensions

0.75" H x 2.5" W x 4"D (2.20 x 6.41 x 10.25 cm)

Ordering Information

McPIM: TP/FO

855-12840	McPIM, TP/FO-MM850, ST, 2 km
855-12841	McPIM, TP/FO-MM850, SC, 2 km
855-12842	McPIM, TP/FO-MM1300, ST, 2 km
855-12843	McPIM, TP/FO-MM1300, SC, 2 km
855-12844	McPIM, TP/FO-SM1310/PLUS, ST, 40 km
855-12845	McPIM, TP/FO-SM1310/PLUS, SC, 40 km
855-12846	McPIM, TP/FO-SM1310/LONG, ST, 70 km
855-12847	McPIM, TP/FO-SM1310/LONG, SC, 70 km
855-12848	McPIM, TP/FO-SM1550/LONG, ST, 80 km
855-12849	McPIM, TP/FO-SM1550/LONG, SC, 80 km

McLIM: TX/FX

855-12662	McLIM, TX/SX-MM850, ST, 2 km
855-12663	McLIM, TX/SX-MM850, SC, 2 km
855-12660	McLIM, TX/FX-MM1300, ST, 2 km
855-12661	McLIM, TX/FX-MM1300, SC, 2 km
855-12664	McLIM, TX/FX-SM1310/PLUS, ST, 40 km
855-12665	McLIM, TX/FX-SM1310/PLUS, SC, 40 km
855-12668	McLIM, TX/FX-SM1310/LONG, SC, 80 km
855-12669	McLIM, TX/FX-SM1550/LONG, SC, 80 km

Single-Strand Fiber

855-12680	McLIM, TX/SSFx-SM1310-SC (1310xmt/1550rcv), 20 km
855-12681	McLIM, TX/SSFx-SM1550-SC (1550xmt/1310rcv), 20 km
855-12682	McLIM, TX/SSFx-SM1310/PLUS-SC (1310xmt/1550rcv), 40 km
855-12683	McLIM, TX/SSFx-SM1550/PLUS-SC (1550xmt/1310rcv), 40 km
855-12684	McLIM, TX/SSFx-SM1310/LONG-SC (1310xmt/1550rcv), 60 km
855-12685	McLIM, TX/SSFx-SM1550/LONG-SC (1550xmt/1310rcv), 60 km

McLIM: TP-TX/FX and TP-TX/SX

855-12620	McLIM, TP-TX/SX-MM850-ST, 550 m
855-12621	McLIM, TP-TX/SX-MM850-SC, 550 m
855-12622	McLIM, TP-TX/FX-MM1300-ST, 2 km
855-12623	McLIM, TP-TX/FX-MM1300-SC, 2 km
855-12624	McLIM, TP-TX/FX-SM1310/PLUS-ST, 40 km
855-12625	McLIM, TP-TX/FX-SM1310/PLUS-SC, 40 km

Single-Strand Fiber

855-12642	McLIM, TP-TX/SSFx-SM1310-SC (1310xmt/1550rcv), 20 km
855-12643	McLIM, TP-TX/SSFx-SM1550-SC (1550xmt/1310rcv), 20 km
855-12644	McLIM, TP-TX/SSFx-SM1310/PLUS-SC (1310xmt/1550rcv), 40 km
855-12645	McLIM, TP-TX/SSFx-SM1550/PLUS-SC (1550xmt/1310rcv), 40 km

McGigabit: TX/SX and TX/LX

855-12670	McGigabit, TX/SX-MM850-SC, 550 m
855-12691	McGigabit, TX/SX-MM1300-SC, 550 m
855-12671	McGigabit, TX/LX-SM1310-SC, 15 km
855-12672	McGigabit, TX/LX-SM1310/PLUS-SC, 40 km
855-12673	McGigabit, TX/LX-SM1550/LONG-SC, 80 km

Single-Strand Fiber

855-12674	McGigabit, TX/SSLX-SM1310-SC (1310xmt/1550rcv), 15 km
855-12675	McGigabit, TX/SSLX-SM1550-SC (1550xmt/1310rcv), 15 km
855-12694	McGigabit, TX/SSBX-SM1310-SC (1310xmt/1490rcv), 10 km
855-12695	McGigabit, TX/SSBX-SM1490-SC (1490xmt/1310rcv), 10 km
855-12676	McGigabit, TX/SSLX-SM1310/PLUS-SC (1310xmt/1550rcv), 40 km
855-12677	McGigabit, TX/SSLX-SM1550/PLUS-SC (1550xmt/1310rcv), 40 km
855-12696	McGigabit, TX/SSBX-SM1310/PLUS-SC (1310xmt/1490rcv), 30 km
855-12697	McGigabit, TX/SSBX-SM1490/PLUS-SC (1490xmt/1310rcv), 30 km
855-12686	McGigabit, TX/SSLX-SM1490/LONG-SC (1490xmt/1550rcv), 60 km
855-12687	McGigabit, TX/SSLX-SM1550/LONG-SC (1550xmt/1490rcv), 60 km
855-12688	McGigabit, TX/SSLX-SM1490/XLONG-SC (1490xmt/1550rcv), 70 km
855-12689	McGigabit, TX/SSLX-SM1550/XLONG-SC (1550xmt/1310rcv), 70 km





McPC Series



Ideal for fiber-to-the-desktop applications, the McPC installs directly inside a PC.

Product Overview

Easily connect fiber to a PC or server with the McPC series of media converters. Installing inside the PC or server, McPC converters are the perfect, low cost alternative to fiber NICs or external media converters.

The McPC series includes:

- **McPC TP/BNC**, converting copper to coax at 10 Mbps
- **McPC 100 Mbps**, converting copper to fiber at 100 Mbps
- **McPC 10/100 Mbps**, converting 10 Mbps copper to 10 Mbps fiber or 100 Mbps copper to 100 Mbps fiber

The McPC series supports 10, 100 & 10/100 protocols and is available for virtually any fiber type, from short-haul multi-mode to long-haul single-mode, with standard ST or SC connectors.

Ease of installation and a variety of Ethernet speed options make the McPC series the perfect solution for FTTD applications and for enterprises with changing requirements such as adding new employees and frequently changing workstation locations.

Features

- Save money by keeping the existing copper NIC and converting inside PC
- No drivers to install; McPC mounts inside any PC or workstation with a standard PCI or ISA slot
- Includes a standard 4-pin peripheral power connector
- Supports Half and Full-Duplex operation
- Includes diagnostic LEDs

Physical Specifications

Fiber Types Supported

- 50/125µm or 62.5/125µm multi-mode fiber
- 9/125µm single-mode fiber
- Available for single-strand fiber

Connectors:

RJ-45, ST and SC

Regulatory Approvals:

FCC Class B, UL/cUL, CSA, CE

Operating Temperature:

+32° to +122°F (0° to +50°C)

Storage Temperature:

-4° to +158°F (-20° to +70°C)

Humidity:

5 to 95% (non-condensing)

Altitude:

0 to 10,000 ft.

Shipping Weight:

0.60 lbs (0.22 kg)

Ordering Information

ISA

McPC TX/FX 100 Mbps

855-13127	McPC/ISA, TX/FX-MM1300, ST, 2 km
855-13128	McPC/ISA, TX/FX-MM1300, SC, 2 km
855-13328	McPC/ISA, TX/FX-SM1310/PLUS, SC, 40 km

McPC 10/100 Mbps

855-13260	McPC/ISA, 10/100-MM850, ST, 2 km
855-13261	McPC/ISA, 10/100-MM850, SC, 2 km
855-13263	McPC/ISA, 10/100-MM1300, SC, 2 km

PCI

McPC TX/FX 100 Mbps

855-12127	McPC/PCI, TX/FX-MM1300, ST, 2 km
855-12128	McPC/PCI, TX/FX-MM1300, SC, 2 km
855-12328	McPC/PCI, TX/FX-SM1310/PLUS, SC, 40 km

McPC 10/100 Mbps

855-12260	McPC/PCI, 10/100-MM850, ST, 2 km
855-12261	McPC/PCI, 10/100-MM850, SC, 2 km
855-12263	McPC/PCI, 10/100-MM1300, SC, 2 km

Available Accessories

806-39230	SATA Cable for McPC
-----------	---------------------

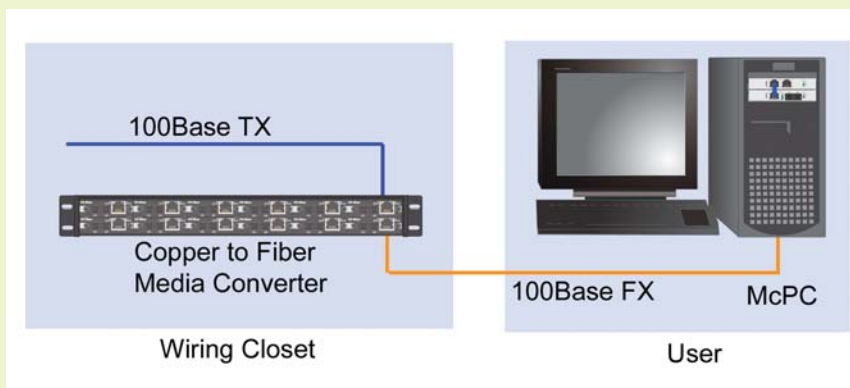



McPC-MediaLinX Series



Ideal for fiber-to-the-desktop applications, the McPC installs directly inside a PC.

Product Overview

Easily connect fiber to a PC or server with the McPC series of converters. Installing inside the PC or server, McPC converters are the perfect, low cost alternative to fiber NICs or external media converters.

The McPC-MediaLinX Series includes:

- **McPC MediaLinX Switching Ethernet**
- A rate converter as well as a media converter, the McPC MediaLinX Switching Ethernet converts 10 or 100 Mbps over copper to 100 Mbps over fiber
- **McPC-Giga-MediaLinX Switching Gigabit Ethernet**
- A rate converter as well as a media converter, the McPC-Giga-MediaLinX Switching converts 10, 100 or 1000 Mbps over copper to 1000 Mbps over fiber

The McPC-MediaLinX series supports 10/100 & 10/100/1000 protocols and is available for virtually any fiber type, from short-haul multi-mode to long-haul single-mode, with standard ST or SC connectors.

Ease of installation and a variety of Ethernet speed options make the McPC-MediaLinX series the perfect solution for FTTD applications and for enterprises with changing requirements such as adding new employees and frequently changing workstation locations.

Features

- Save money by keeping the existing copper NIC and converting inside PC
- No drivers to install; McPC-MediaLinX and McPC-Giga-MediaLinX mounts inside any PC or workstation with a standard PCI or ISA slot
- Includes a standard 4-pin peripheral power connector
- Supports Half and Full-Duplex operation
- Includes diagnostic LEDs

Physical Specifications

Fiber Types Supported

- 50/125µm or 62.5/125µm multi-mode fiber
- 9/125µm single-mode fiber
- Available for single-strand fiber

Connectors:

RJ-45, ST and SC

Regulatory Approvals:

FCC Class B, CE

Operating Temperature:

+32° to +122°F (0° to +50°C)

Storage Temperature:

-4° to +158°F (-20° to +70°C)

Humidity:

5 to 95% (non-condensing)

Altitude:

0 to 10,000 ft.

Shipping Weight:

0.60 lbs (0.22 kg)

Ordering Information

ISA

McPC-MediaLinX Switching Ethernet (10/100 Mbps)

855-13731 McPC/ISA-MediaLinX, MM850, SC, 2 km

855-13732 McPC/ISA-MediaLinX, MM1300, ST, 2 km

PCI

McPC-MediaLinX Switching Ethernet (10/100 Mbps)

855-12731 McPC/PCI-MediaLinX, MM850-SC, 2 km

855-12732 McPC/PCI-MediaLinX, MM1300-ST, 2 km

855-12733 McPC/PCI-MediaLinX, MM1300-SC, 2 km

McPC-Giga-MediaLinX Switching Ethernet (10/100/1000 Mbps)

855-12920 McPC/PCI-Giga-MediaLinX, TX/SX-MM850, SC 550 m

855-12921 McPC/PCI-Giga-MediaLinX, TX/LX-SM1300, SC 15 km

855-12922 McPC/PCI-Giga-MediaLinX, TX/LX-SM1310/PLUS, SC 40 km

855-12924 McPC/PCI-Giga-MediaLinX, TX/LX-SM1550/LONG, SC, 70 km

Single-Strand Fiber

855-12927 McPC/PCI-Giga-MediaLinX, TX/SSLX-SM1310, SC, 15 km

855-12928 McPC/PCI-Giga-MediaLinX, TX/SSLX-SM1550, SC, 15 km

855-12929 McPC/PCI-Giga-MediaLinX, TX/SSLX-SM1310/PLUS, SC, 40 km

855-12930 McPC/PCI-Giga-MediaLinX, TX/SSLX-SM1550/LONG, SC, 40 km

Available Accessories

806-39230 SATA Cable for McPC

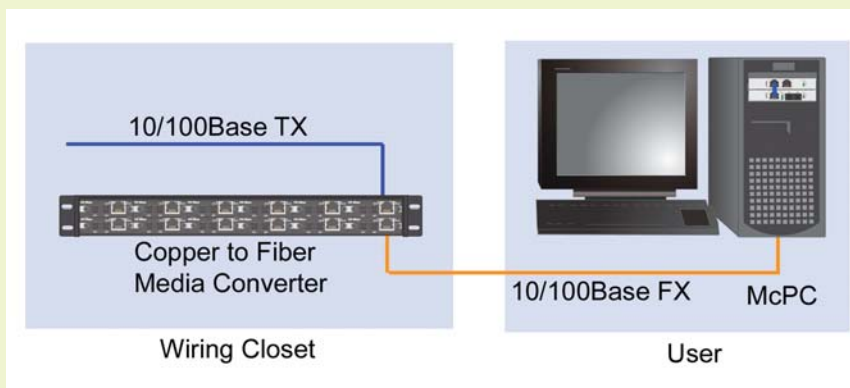



McPC-Gigabit Series

6-YEAR
Comprehensive
Warranty



Ideal for fiber-to-the-desktop applications, the McPC installs directly inside a PC.

Product Overview

Easily connect fiber to a PC or server with the McPC series of converters. Installing inside the PC or server, McPC converters are the perfect, low cost alternative to fiber NICs or external media converters.

The McPC-Gigabit series includes:

- **McPC-Gigabit**, converting copper to fiber at 1.25 Gbps

The McPC-Gigabit series supports Gigabit protocols and is available for virtually any fiber type, from short-haul multi-mode to long-haul single-mode, with standard SC connectors.

Ease of installation and a variety of distance options make the McPC-Gigabit series the perfect solution for FTTD applications and for enterprises with changing requirements such as adding new employees and frequently changing workstation locations.

Features

- Save money by keeping the existing copper NIC and converting inside PC
- No drivers to install; McPC-Gigabit mounts inside any PC or workstation with a standard PCI slot
- Includes a standard 4-pin peripheral power connector
- Supports Half and Full-Duplex operation
- Includes diagnostic LEDs

Physical Specifications

Fiber Types Supported

- 50/125µm or 62.5/125µm multi-mode fiber
- 9/125µm single-mode fiber
- Available for single-strand fiber

Connectors:

RJ-45, ST and SC

Regulatory Approvals:

FCC Class B, CE

Operating Temperature:

+32° to +122°F (0° to +50°C)

Storage Temperature:

-4° to +158°F (-20° to +70°C)

Humidity:

5 to 95% (non-condensing)

Altitude:

0 to 10,000 ft.

Shipping Weight:

0.60 lbs (0.22 kg)

Ordering Information

PCI

McPC-Gigabit

855-12900	McPC/PCI-Gigabit, TX/SX-MM850-SC, 550 m
855-12901	McPC/PCI-Gigabit, TX/LX-SM1310-SC, 15 km
855-12902	McPC/PCI-Gigabit, TX/LX-SM1310/PLUS-SC, 40 km
855-12903	McPC/PCI-Gigabit, TX/LX-SM1550/LONG-SC, 70 km
Single-Strand Fiber	
855-12904	McPC/PCI-Gigabit, TX/SSLX-SM1310-SC (1310xmt/1550rcv), 15 km
855-12905	McPC/PCI-Gigabit, TX/SSLX-SM1550-SC (1550xmt/1310rcv), 15 km
855-12906	McPC/PCI-Gigabit, TX/SSLX-SM1310/PLUS-SC (1310xmt/1550rcv), 40 km
855-12907	McPC/PCI-Gigabit, TX/SSLX-SM1550/PLUS-SC (1550xmt/1310rcv), 40 km

Available Accessories

806-39230	SATA Cable for McPC
-----------	---------------------

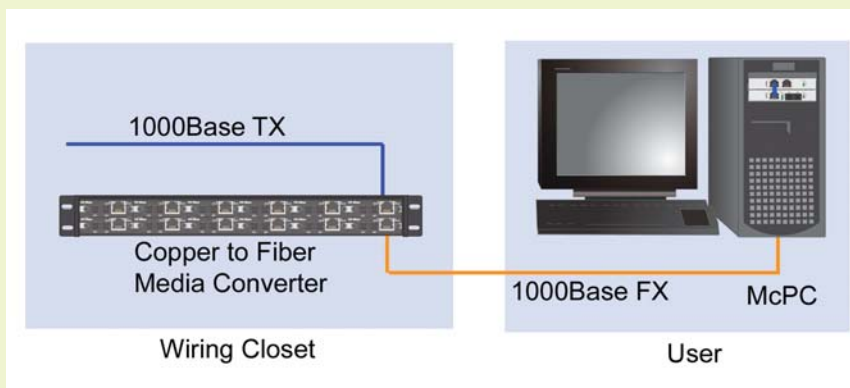

WDM Series

6-YEAR
Comprehensive
Warranty



With WDM products, service providers and enterprise network managers can easily double fiber capacity and integrate multiple protocols.

Product Overview

Wavelength Division Multiplexing (WDM) is a technology that enables the transmitting of multiple, optical signals on different wavelengths over one strand of fiber. The series is designed for installations where fiber is limited in terms of availability. Service providers and enterprise network managers can easily double their fiber capacity without incurring the costs associated with installing new fiber. Campus area network managers can deploy the IMC Networks WDM solution, for example, to combine voice and data traffic over the same duplex fiber between company facilities.

Protocol and speed-independent; available in standalone and modular versions

The WDM/2 and iMcV-WDM are two-channel, passive, protocol and speed-independent Wavelength Division Multiplexers that allow two individual wavelengths to share one fiber pair; Full-Duplex data travels on 1310 nm and 1550 nm to virtually double the capacity of installed fiber. Deploy WDM products in pairs so that the host site will multiplex 1310 nm and 1550 nm onto the fiber and the remote site will then separate the signals by the wavelength. Available in standalone and modular versions, protocol-independent WDM products enable the transmitting of any protocol and any speed over 1310 nm or 1550 nm single-mode fiber.

Supports a variety of protocols; easy installation

As passive, protocol-independent Wavelength Division Multiplexers, WDM/2 and iMcV-WDM comply with a wide range of communications protocols including Ethernet (10/100/1000 Mbps), SONET/SDH (OC-3, OC-12, OC-48), FDDI, ATM, ESCON, T1/E1, E3, DS3 and Fibre Channel. Installing WDM products is easy — the standalone WDM/2 chassis comes ready to install and iMcV-WDM modules slide into any IMC Networks iMediaChassis or MediaChassis/2. No configuration is required for either version.

Application Example

Connect two fiber network segments using a single strand.

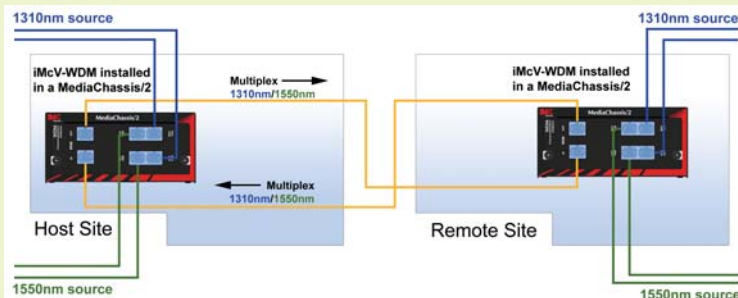

Features

Leverages investment on existing fiber infrastructure

- Doubles the capacity of installed fiber by transmitting two wavelengths on one strand of fiber

Supports multiple protocols

- Speed and protocol-independent, supporting 1310 nm and 1550 nm single-mode fiber

Easy to install - no configuration

- Just slide the iMcV-WDM/2 into a chassis and match the fiber connectors with the 1310 nm and 1550 nm wavelengths
- WDM/2 chassis performs multiplexing with NO outside power requirement
- Requires two slots in a chassis; modules are double-wide

Maximizes network uptime

- Modular, hot-swappable architecture reduces operational costs associated with product installation, upgrades and maintenance

Physical Specifications

Fiber Types Supported

- 50/125µm or 62.5/125µm multi-mode fiber
- 9/125µm single-mode fiber
- Available for single-strand fiber

Connectors:

SC

Regulatory Approvals:

FCC Class A, UL/cUL, CSA, CE

Operating Temperature:

+32° to +122°F (0° to +50°C)

Storage Temperature:

-13° to +158°F (-25° to +70°C)

Humidity:

5 to 95% (non-condensing)

Altitude:

0 to 10,000 ft.

Shipping Weight:

0.9 lbs (0.34 kg) Module

1.1 lbs (0.50 kg) Standalone Chassis

Ordering Information

iMcV-WDM/2 (Double Wide Module)

849-14100 iMcV-WDM/2-SM1310-SC

iMcV-WDM/2 (Stand Alone Chassis)

849-10100 WDM/2-SM1310-SC



iMcV-PIM, iMcV-LIM Modules



Monitor and control all connections from a central site with SNMP-manageable “iMcV-“ media conversion modules.

Product Overview

Satisfying today’s networking needs while preparing for tomorrow’s cabling requirements can make designing and installing the physical layer of networks a daunting task. The decreasing cost of fiber optic cabling and switching equipment makes all-optical LANs the obvious choice when future-proofing network equipment. Replacing legacy equipment and wiring infrastructure is a costly choice. Managed media conversion allows implementation of new technologies on existing networks, while monitoring all connections, to keep networks running and up-to-date.

IMC Networks offers a wide range of SNMP-managed Ethernet copper to fiber media converters, with a choice of fixed rate or rate conversion capabilities. The “iMcV-“ modules also include troubleshooting features and LEDs to assist in network diagnostics as well as make isolating cable breaks easier. The 100 Mbps iMcV-Lim also features Link Fault Pass-Through. In addition, replacing the hot-swappable modules won’t disable other modules services running within the same chassis during product upgrades or maintenance and troubleshooting.

All converters feature an RJ-45 copper port and a fiber port, with a choice of SC or ST connectors.

“iMcV-“ media converters include:

- iMcV-PIM - convert 10 Mbps copper to 10 Mbps fiber
- iMcV-LIM - convert 100 Mbps copper to 100 Mbps fiber
- iMcV-LIM 10/100 - convert 10 Mbps copper to 10 Mbps fiber or 100 Mbps copper to 100 Mbps fiber

Features

Meets a variety of installation requirements

- Choose from a wide range of speeds up to Fast Ethernet
- Available for multi-mode or single-mode fiber
- Double fiber capacity with single-strand fiber versions
- Supports very long fiber distances

Easy to configure and manage with GUI-based iView²

- Up and running in less than five minutes
- Monitor links and receive vital traffic and health information and notification should problems occur

Maximizes network uptime

- Modular, hot-swappable architecture reduces operational costs associated with product installation, upgrades and maintenance

Physical Specifications

Fiber Types Supported

- 50/125µm or 62.5/125µm multi-mode fiber
- 9/125µm single-mode fiber
- Available for single-strand fiber

Connectors:

RJ-45, ST and SC

Regulatory Approvals:

FCC Class B, CE

Operating Temperature:

+32° to +122°F (0° to +50°C)

Storage Temperature:

-13° to +158°F (-25° to +70°C)

Humidity:

5 to 95% (non-condensing)

Altitude:

0 to 10,000 ft.

Dimensions

4.19”H x 0.78”W x 2.75”D (10.74 x 2 x 7.05 cm)

Shipping Weight:

0.30 lbs (0.11 kg)

Ordering Information

iMcV-PIM 10 Mbps

850-14940	iMcV-PIM, TP/FO-MM850-ST, 2 km
850-14941	iMcV-PIM, TP/FO-MM850-SC, 2 km
850-14942	iMcV-PIM, TP/FO-MM1300-ST, 2 km
850-14943	iMcV-PIM, TP/FO-MM1300-SC, 2 km
850-14944	iMcV-PIM, TP/FO-SM1310/PLUS-ST, 40 km
850-14945	iMcV-PIM, TP/FO-SM1310/PLUS-SC, 40 km
850-14946	iMcV-PIM, TP/FO-SM1310/LONG-ST, 70 km
850-14947	iMcV-PIM, TP/FO-SM1310/LONG-SC, 70 km
850-14949	iMcV-PIM, TP/FO-SM1550/LONG-SC, 80 km

* iMcV-LIM TX/FX 100 Mbps with Link Fault Pass-Through (LFPT)

850-11920	iMcV-LIM, TX/FX-MM1300-ST, 2 km
850-11921	iMcV-LIM, TX/FX-MM1300-SC, 2 km
850-11922	iMcV-LIM, TX/FX-MM850-ST, 2 km
850-11926	iMcV-LIM, TX/FX-SM1310/PLUS-ST, 40 km
850-11927	iMcV-LIM, TX/FX-SM1310/PLUS-SC, 40 km
850-11932	iMcV-LIM, TX/FX-SM1310/LONG-ST, 80 km
850-11933	iMcV-LIM, TX/FX-SM1310/LONG-SC, 80 km
850-11931	iMcV-LIM, TX/FX-SM1550/LONG-SC, 80 km

Single-Strand Fiber

849-11720	iMcV-LIM, TX/SSFx-MM1310-SC (1310xmt/1550rcv), 2 km
849-11721	iMcV-LIM, TX/SSFx-SM1550-SC (1550xmt/1310rcv), 2 km
849-11714	iMcV-LIM, TX/SSFx-SM1310-SC (1310xmt/1550rcv), 20 km
849-11715	iMcV-LIM, TX/SSFx-SM1550-SC (1550xmt/1310rcv), 20 km
849-11716	iMcV-LIM, TX/SSFx-SM1310/PLUS-SC (1310xmt/1550rcv), 40 km
849-11717	iMcV-LIM, TX/SSFx-SM1550/PLUS-SC (1550xmt/1310rcv), 40 km
849-11718	iMcV-LIM, TX/SSFx-SM1310/LONG-SC (1310xmt/1550rcv), 60 km
849-11719	iMcV-LIM, TX/SSFx-SM1550/LONG-SC (1550xmt/1310rcv), 60 km

iMcV-LIM TX/FX 10/100 Mbps

850-14260	iMcV-LIM, 10/100-MM850-ST, 2 km
850-14261	iMcV-LIM, 10/100-MM850-SC, 2 km
850-14262	iMcV-LIM, 10/100-MM1300-ST, 2 km
850-14263	iMcV-LIM, 10/100-MM1300-SC, 2 km
850-14267	iMcV-LIM, 10/100-SM1310/PLUS-ST, 40 km
850-14268	iMcV-LIM, 10/100-SM1310/PLUS-SC, 40 km
850-14269	iMcV-LIM, 10/100-SM1310/LONG-ST, 80 km
850-14270	iMcV-LIM, 10/100-SM1310/LONG-SC, 80 km
850-14274	iMcV-LIM, 10/100-SM1550/LONG-SC, 80 km

Use with Chassis Platform

iMediaChassis Series, See Page 33
MediaChassis Series, See Page 34
IE-MediaChassis Series, See Page 34

CWDM version available,
Call IMC Networks for details



iMcV-Gigabit Modules



Monitor and control all connections from a central site with SNMP-manageable “iMcV-“ media conversion modules.

Product Overview

Satisfying today's networking needs while preparing for tomorrow's cabling requirements can make designing and installing the physical layer of networks a daunting task. The decreasing cost of fiber optic cabling and switching equipment makes all-optical LANs the obvious choice when future-proofing network equipment. Replacing legacy equipment and wiring infrastructure is a costly choice. Managed media conversion allows implementation of new technologies on existing networks, while monitoring all connections, to keep networks running and up-to-date.

IMC Networks offers a range of SNMP-managed Ethernet copper to fiber media converters, with a choice of fixed rate or rate conversion capabilities. The “iMcV-“ modules also include troubleshooting features and LEDs to assist in network diagnostics as well as make isolating cable breaks easier. In addition, replacing the hot-swappable modules won't disable other modules services running within the same chassis, during product upgrades or maintenance and troubleshooting.

All converters feature an RJ-45 copper port and a fiber port with SC connectors.

“iMcV-“ media converters include:

- iMcV-Gigabit - convert copper to fiber at a data rate of up to 1.25 Gbps

Features

Meets a variety of installation requirements

- Available for multi-mode or single-mode fiber
- Double fiber capacity with single-strand fiber versions
- Supports very long fiber distances

Easy to configure and manage with GUI-based iView²

- Up and running in less than five minutes
- Monitor links and receive vital traffic and health information and notification should problems occur

Maximizes network uptime

- Modular, hot-swappable architecture reduces operational costs associated with product installation, upgrades and maintenance

Physical Specifications

Fiber Types Supported

- 50/125µm or 62.5/125µm multi-mode fiber
- 9/125µm single-mode fiber
- Available for single-strand fiber

Connectors:

RJ-45, ST and SC

Regulatory Approvals:

FCC Class A, CE

Operating Temperature:

+32° to +122°F (0° to +50°C)

Storage Temperature:

-13° to +158°F (-25° to +70°C)

Humidity:

5 to 95% (non-condensing)

Altitude:

0 to 10,000 ft.

Dimensions

4.19”H x 0.78”W x 2.75”D (10.74 x 2 x 7.05 cm)

Shipping Weight:

0.30 lbs (0.11 kg)

Ordering Information

IE-iMcV-Gigabit TX/SFP 1000 Mbps with Link Fault Pass-Through (LFPT)

850-18912 IE-iMcV-Gigabit, TX/SFP (requires one IE-SFP/1250 module)

iMcV-Gigabit TX/FX 1000 Mbps with Link Fault Pass-Through (LFPT)

850-11913 iMcV-Gigabit, TX/SX-MM850-SC, 550 m

850-11914 iMcV-Gigabit, TX/LX-SM1310-SC, 15 km

850-11915 iMcV-Gigabit, TX/LX-SM1310/PLUS-SC, 40 km

850-11917 iMcV-Gigabit, TX/LX-SM1550/LONG-SC, 80 km

850-11918 iMcV-Gigabit, TX/LX-SM1550/XLONG-SC, 100 km

Single-Strand Fiber

850-11844 iMcV-Gigabit, TX/SSLX-SM1310-SC (1310xmt/1550rcv), 15 km

850-11845 iMcV-Gigabit, TX/SSLX-SM1550-SC (1550xmt/1310rcv), 15 km

850-11834 iMcV-Gigabit, TX/SSBX-SM1310-SC (1310xmt/1490rcv), 10 km

850-11835 iMcV-Gigabit, TX/SSBX-SM1490-SC (1490xmt/1310rcv), 10 km

850-11846 iMcV-Gigabit, TX/SSLX-SM1310/PLUS-SC (1310xmt/1550rcv), 30 km

850-11847 iMcV-Gigabit, TX/SSLX-SM1550/PLUS-SC (1550xmt/1310rcv), 30 km

850-11836 iMcV-Gigabit, TX/SSBX-SM1310/PLUS-SC (1310xmt/1490rcv), 30 km

850-11837 iMcV-Gigabit, TX/SSBX-SM1490/PLUS-SC (1490xmt/1310rcv), 30 km

850-11848 iMcV-Gigabit, TX/SSLX-SM1490/LONG-SC (1490xmt/1550rcv), 60 km

850-11849 iMcV-Gigabit, TX/SSLX-SM1550/LONG-SC (1550xmt/1490rcv), 60 km

850-11850 iMcV-Gigabit, TX/SSLX-SM1490/XLONG-SC (1490xmt/1550rcv), 70 km

850-11851 iMcV-Gigabit, TX/SSLX-SM1550/XLONG-SC (1550xmt/1490rcv), 70 km

Use with Chassis Platform

iMediaChassis Series, See Page 33

MediaChassis Series, See Page 34

IE-MediaChassis Series, See Page 34

CWDM version available,
Call IMC Networks for details



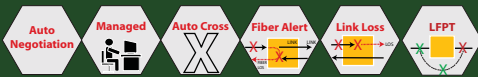

Rate Converting 10/100 Mbps and 10/100/1000 Mbps Modular Converters

iMcV-MediaLinX, iMcV-Giga-MediaLinX Modules



Monitor and control all connections from a central site with SNMP-manageable “iMcV-“ media conversion modules.

Product Overview

Satisfying today's networking needs while preparing for tomorrow's cabling requirements can make designing and installing the physical layer of networks a daunting task. The decreasing cost of fiber optic cabling and switching equipment makes all-optical LANs the obvious choice when future-proofing network equipment. Replacing legacy equipment and wiring infrastructure is a costly choice. Managed media conversion allows implementation of new technologies on existing networks, while monitoring all connections, to keep networks running and up-to-date.

IMC Networks offers a wide range of SNMP-managed Ethernet copper to fiber media converters, with a choice of fixed rate or rate conversion capabilities. The “iMcV-“ modules also include troubleshooting features and LEDs to assist in network diagnostics as well as make isolating cable breaks easier. The iMcV-MediaLinX and iMcV-Giga-MediaLinX also features Link Fault Pass-Through. In addition, replacing the hot-swappable modules won't disable other modules services running within the same chassis, during product upgrades or maintenance and troubleshooting.

All converters feature an RJ-45 copper port and a fiber port, with a choice of SC or ST (non-Gigabit only) connectors.

“iMcV-“ media and rate converters include:

- iMcV-MediaLinX – convert 10 Mbps or 100 Mbps copper to 100 Mbps fiber
- iMcV-Giga-MediaLinX – convert 10 Mbps, 100 Mbps or 1000 Mbps copper to 1000 Mbps fiber

Rate converters employ Auto Negotiation functionality on the twisted pair port for plug-and-play operation, or they can be manually configured for the desired speed and duplex mode.

Features

Meets a variety of installation requirements

- Choose from a range of speeds up to Gigabit Ethernet
- Available for multi-mode or single-mode fiber
- Double fiber capacity with single-strand fiber versions
- Supports very long fiber distances

Easy to configure and manage with GUI-based iView²

- Up and running in less than five minutes
- Monitor links and receive vital traffic and health information and notification should problems occur

Maximizes network uptime

- Modular, hot-swappable architecture reduces operational costs associated with product installation, upgrades and maintenance

Physical Specifications

Fiber Types Supported

- 50/125µm or 62.5/125µm multi-mode fiber
- 9/125µm single-mode fiber
- Available for single-strand fiber

Connectors:

RJ-45, ST and SC

Regulatory Approvals:

FCC Class B, CE

Operating Temperature:

+32° to +122°F (0° to +50°C)

Storage Temperature:

-13° to +158°F (-25° to +70°C)

Humidity:

5 to 95% (non-condensing)

Altitude:

0 to 10,000 ft.

Dimensions

4.19"H x 0.78"W x 2.75"D (10.74 x 2 x 7.05 cm)

Shipping Weight:

0.30 lbs (0.11 kg)

Use with Chassis Platform

iMediaChassis Series, See Page 33
MediaChassis Series, See Page 34
IE-MediaChassis Series, See Page 34

Ordering Information

IE-iMcV-MediaLinX TX/SFP 10/100 Mbps with Link Fault Pass-Through (LFPT)

856-18901 IE-iMcV-MediaLinX, TX/SFP (requires one SFP/155-ED Module required)

iMcV-MediaLinX TX/FX 10/100 Mbps with Link Fault Pass-Through (LFPT)

856-11913	iMcV-MediaLinX, TX/FX-MM850-ST, 2 km
856-11914	iMcV-MediaLinX, TX/FX-MM850-SC, 2 km
856-11911	iMcV-MediaLinX, TX/FX-MM1300-ST, 2 km
856-11912	iMcV-MediaLinX, TX/FX-MM1300-SC, 2 km
856-11915	iMcV-MediaLinX, TX/FX-SM1310/PLUS-ST, 40 km
856-11916	iMcV-MediaLinX, TX/FX-SM1310/PLUS-SC, 40 km
856-11917	iMcV-MediaLinX, TX/FX-SM1310/LONG-ST, 80 km
856-11918	iMcV-MediaLinX, TX/FX-SM1310/LONG-SC, 80 km
856-11921	iMcV-MediaLinX, TX/FX-SM1550/LONG-SC, 80 km

Single-Strand Fiber

856-11944	iMcV-MediaLinX, TX/SSFx-SM1310-SC (1310xmt/1550rcv), 20 km
856-11945	iMcV-MediaLinX, TX/SSFx-SM1550-SC (1550xmt/1310rcv), 20 km
856-11946	iMcV-MediaLinX, TX/SSFx-SM1310/PLUS-SC (1310xmt/1550rcv), 40 km
856-11947	iMcV-MediaLinX, TX/SSFx-SM1550/PLUS-SC (1550xmt/1310rcv), 40 km
856-11948	iMcV-MediaLinX, TX/SSFx-SM1310/LONG-SC (1310xmt/1550rcv), 60 km
856-11949	iMcV-MediaLinX, TX/SSFx-SM1550/LONG-SC (1550xmt/1310rcv), 60 km

iMcV-Giga-MediaLinX TX/FX 10/100/1000 Mbps with Link Fault Pass-Through (LFPT)

856-11950	iMcV-Giga-MediaLinX, TX/SX-MM850-SC, 550 m
856-11951	iMcV-Giga-MediaLinX, TX/LX-SM1310-SC, 15 km
856-11952	iMcV-Giga-MediaLinX, TX/LX-SM1310/PLUS-SC, 40 km
856-11953	iMcV-Giga-MediaLinX, TX/LX-SM1550/LONG-SC, 80 km
856-11958	iMcV-Giga-MediaLinX, TX/LX-SM1550/XLONG-SC, 100 km

Single-Strand Fiber

856-11940	iMcV-Giga-MediaLinX, TX/SSLX-SM1310-SC (1310xmt/1550rcv), 15 km
856-11941	iMcV-Giga-MediaLinX, TX/SSLX-SM1550-SC (1550xmt/1310rcv), 15 km
856-11933	iMcV-Giga-MediaLinX, TX/SSBX-SM1310-SC (1310xmt/1490rcv), 10 km
856-11935	iMcV-Giga-MediaLinX, TX/SSBX-SM1490-SC (1490xmt/1310rcv), 10 km
856-11942	iMcV-Giga-MediaLinX, TX/SSLX-SM1310/PLUS-SC (1310xmt/1550rcv), 40 km
856-11943	iMcV-Giga-MediaLinX, TX/SSLX-SM1550/PLUS-SC (1550xmt/1310rcv), 40 km
856-11937	iMcV-Giga-MediaLinX, TX/SSBX-SM1310/PLUS-SC (1310xmt/1490rcv), 30 km
856-11939	iMcV-Giga-MediaLinX, TX/SSBX-SM1490/PLUS-SC (1490xmt/1310rcv), 30 km
856-11954	iMcV-Giga-MediaLinX, TX/SSLX-SM1490/LONG-SC (1490xmt/1550rcv), 60 km
856-11955	iMcV-Giga-MediaLinX, TX/SSLX-SM1550/LONG-SC (1550xmt/1490rcv), 60 km
856-11956	iMcV-Giga-MediaLinX, TX/SSLX-SM1490/XLONG-SC (1490xmt/1550rcv), 70 km
856-11957	iMcV-Giga-MediaLinX, TX/SSLX-SM1550/XLONG-SC (1550xmt/1490rcv), 70 km

CWDM version available, Call IMC Networks for details





iMcV-T1/E1/J1 Modules



The ideal solution for extending PBX or legacy Telco circuits over fiber optics in the local loop and or long-haul applications.

Product Overview

SNMP-manageable, the iMcV-T1/E1/J1 converter series of modules extend 1.544 Mbps T1/J1 and 2.048 Mbps E1 copper-based PBX, router and switch circuits over regular duplex fiber or single-strand fiber optics. Supporting fiber distances of up to 80 km, the iMcV-T1/E1/J1 series of converters include built-in jitter removal, line integrity testing, diagnostic tools (Loopback mode and Transmit Data Source) and remote management features.

Select from the iMcV-T1/E1/J1, offering standard repeater-like functionality, or the iMcV-T1/E1/J1-LineTerm which incorporates advanced features such as Line Terminating functionality, support for both Alarm Indication Signals (AIS) and Remote Alarm Indications (RAI). Both versions are designed to be installed in pairs.

The iMcV-T1/E1/J1 LineTerm modules are installed as a HOST-REMOTE pair and can be remotely managed when the HOST is installed in an iMediaChassis with an SNMP-Management Module. This enables network managers to conduct loopback testing, to monitor, and to manage units located up to 80 km away.

Application Example

Extend T1/E1/J1 signals up to 80 km over fiber using point to point iMcV-T1/E1/J1 modules. In the example below, PBX traffic from a local office is sent over fiber to a remote data center.

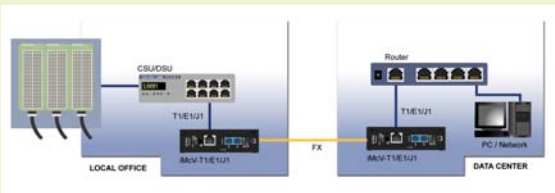

Features

Switch Selectable Protocol

- Operates at (T1/J1 1.544 Mbps) and (E1 2.048 Mbps)

Two versions to choose from:

- Standard version – offers repeater-like functionality
- Line Terminating version – supports “Telco-like” features, including Alarm Indication Signals (AIS) and Remote Alarm Indications (RAI)

Management

- Conduct Loopback tests, monitor/manage units via GUI-based iView2
- Remote unit supports secure, out-of-band management
- Diagnostic LEDs

Offers more fiber choices

- Available for multi-mode or single-mode fiber
- Single-strand fiber versions
- Supports distances up to 80 km

Eases troubleshooting

- Loopback testing modes, plus SNMP management and LEDs, assist in diagnosing problems on fiber optic or copper networks
- Supports fiber and coax remote loopback control
- Transmit Data Source diagnostic tool sends data as unframed all ones, a pattern of alternating ones and zeros, or a Pseudorandom Bit Sequence (PRBS). A built-in PRBS signal detector makes testing even easier.
- LED display for monitoring of line diagnostics

Physical Specifications

Fiber Types Supported

- 50/125µm or 62.5/125µm multi-mode fiber
- 9/125µm single-mode fiber
- Available for single-strand fiber

Connectors:

RJ-48, ST and SC

Regulatory Approvals:

FCC Class A, UL/cUL, CE, CSA, CB

Operating Temperature:

+32° to +122°F (0° to +50°C)

Storage Temperature:

-13° to +158°F (-25° to +70°C)

Humidity:

5 to 95% (non-condensing)

Altitude:

0 to 10,000 ft.

Dimensions

4.19”H x 0.78”W x 2.75”D (10.74 x 2 x 7.05 cm)

Power Rating:

5V

Shipping Weight:

0.30 lbs (0.11 kg)

Ordering Information

iMcV-T1/E1/J1 Repeater Modules

850-14198	iMcV-T1/E1/J1, TP/Fiber-MM850-ST, 2 km
850-14199	iMcV-T1/E1/J1, TP/Fiber-MM850-SC, 2 km
850-14200	iMcV-T1/E1/J1, TP/Fiber-MM1300-ST, 2 km
850-14201	iMcV-T1/E1/J1, TP/Fiber-MM1300-SC, 2 km
850-14202	iMcV-T1/E1/J1, TP/Fiber-SM1310/PLUS-ST, 40 km
850-14203	iMcV-T1/E1/J1, TP/Fiber-SM1310/PLUS-SC, 40 km
850-14204	iMcV-T1/E1/J1, TP/Fiber-SM1310/LONG-ST, 80 km
850-14205	iMcV-T1/E1/J1, TP/Fiber-SM1310/LONG-SC, 80 km
850-14206	iMcV-T1/E1/J1, TP/Fiber-SM1550/LONG-SC, 80 km

Single-Strand Fiber

850-14288	iMcV-T1/E1/J1, TP/SSFiber-MM1310-SC (1310xmt/1550rcv), 2 km
850-14289	iMcV-T1/E1/J1, TP/SSFiber-MM1550-SC (1550xmt/1310rcv), 2 km
850-14290	iMcV-T1/E1/J1, TP/SSFiber-SM1310-SC (1310xmt/1550rcv), 20 km
850-14291	iMcV-T1/E1/J1, TP/SSFiber-SM1550-SC (1550xmt/1310rcv), 20 km
850-14292	iMcV-T1/E1/J1, TP/SSFiber-SM1310/PLUS-SC (1310xmt/1550rcv), 40 km
850-14293	iMcV-T1/E1/J1, TP/SSFiber-SM1550/PLUS-SC (1550xmt/1310rcv), 40 km
850-14294	iMcV-T1/E1/J1, TP/SSFiber-SM1310/LONG-SC (1310xmt/1550rcv), 60 km
850-14295	iMcV-T1/E1/J1, TP/SSFiber-SM1550/LONG-SC (1550xmt/1310rcv), 60 km

iMcV-T1/E1/J1 Line Terminating Modules

850-14101	iMcV-T1/E1/J1-LineTerm TP/Fiber-MM850-ST, 2 km
850-14102	iMcV-T1/E1/J1-LineTerm TP/Fiber-MM850-SC, 2 km
850-14103	iMcV-T1/E1/J1-LineTerm TP/Fiber-MM1300-ST, 2 km
850-14104	iMcV-T1/E1/J1-LineTerm TP/Fiber-MM1300-SC, 2 km
850-14105	iMcV-T1/E1/J1-LineTerm TP/Fiber-SM1310/PLUS-ST, 40 km
850-14106	iMcV-T1/E1/J1-LineTerm TP/Fiber-SM1310/PLUS-SC, 40 km
850-14107	iMcV-T1/E1/J1-LineTerm TP/Fiber-SM1310/LONG-ST, 80 km
850-14108	iMcV-T1/E1/J1-LineTerm TP/Fiber-SM1310/LONG-SC, 80 km
850-14110	iMcV-T1/E1/J1-LineTerm TP/Fiber-SM1550/LONG-ST, 80 km

Single-Strand Fiber

850-14120	iMcV-T1/E1/J1-LineTerm TP/SSFiber-MM1310-SC (1310xmt/1550rcv), 2 km
850-14121	iMcV-T1/E1/J1-LineTerm TP/SSFiber-MM1550-SC (1550xmt/1310rcv), 2 km
850-14122	iMcV-T1/E1/J1-LineTerm TP/SSFiber-SM1310-SC (1310xmt/1550rcv), 20 km
850-14123	iMcV-T1/E1/J1-LineTerm TP/SSFiber-SM1550-SC (1550xmt/1310rcv), 20 km
850-14124	iMcV-T1/E1/J1-LineTerm TP/SSFiber-SM1310/PLUS-SC (1310xmt/1550rcv), 40 km
850-14125	iMcV-T1/E1/J1-LineTerm TP/SSFiber-SM1550/PLUS-SC (1550xmt/1310rcv), 40 km
850-14126	iMcV-T1/E1/J1-LineTerm TP/SSFiber-SM1310/LONG-SC (1310xmt/1550rcv), 60 km
850-14127	iMcV-T1/E1/J1-LineTerm TP/SSFiber-SM1550/LONG-SC (1550xmt/1310rcv), 60 km

Use with Chassis Platform

iMediaChassis Series, See Page 33

MediaChassis Series, See Page 34

IE-MediaChassis Series, See Page 34

CWDM version available,
Call IMC Networks for details





DS3/E3/STS Modular Converters

iMcV-DS3/E3/STS



Protocol-selectable DS3/E3/STS Coax-to-Fiber media converters extend transmission distances over fiber optics and reduces operational costs with remote end management.

Product Overview

iMcV-DS3/E3/STS converters are perfect for service providers and enterprise campus networks utilizing DS3/E3/STS coaxial circuits. The modules enable users to convert coax media to single-mode fiber and extend the distance of data transmissions over MAN access networks up to 80 km. The modules support premises networking applications to convert the incoming circuit to fiber for distribution into the structured cabling system.

Choose from versions offering repeater-like functionality or Line-Terminating functionality, including standards compliant Alarm Indication Signals (AIS) for signal loss condition propagation.

The iMcV-DS3/E3/STS LineTerm modules are installed as a HOST-REMOTE pair and can be remotely managed when the HOST is installed in an iMediaChassis with an SNMP-Management Module. This enables network managers to conduct loopback testing, to monitor, and to manage units located up to 80 km away. Since IMC Networks' management technology functions transparently to the user data, real-time, end-to-end management is provided at all times.

Application Example

Extend DS3 signals up to 80 km over fiber optics using iMcV-DS3/E3/STS converters

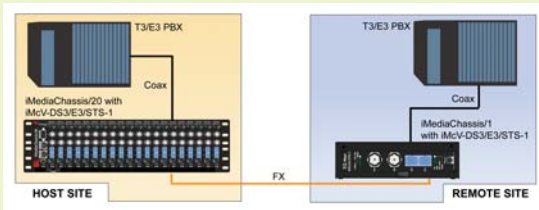

* For telco environments, it is not recommended that the iMcV-DS3/E3/STS converters be installed in an IE-MediaChassis/1-DC. The power source in this chassis is not isolated, and cannot support positive reference ground systems typically used in Telco environments. The MediaChassis/2-DC and the iMediaChassis/6-DC are suitable alternatives.

Features

Switch Selectable Protocol

- Operates at 45 Mbps (DS3), 34 Mbps (E3) or 52 Mbps (STS-1)
- Two versions to choose from:
 - Standard Version - offers repeater-like functionality
 - Line Terminating Version - supports "Telco" features, including Alarm Indication Signals (AIS)

Management

- Conduct loopback tests, monitor/manage units via GUI-Based iView²
- Remote unit supports secure, out-of-band management
- Diagnostic LEDs

Supports more fiber choices

- Available for multi-mode or single-mode fiber
- Single-strand fiber versions
- Supports very long fiber distances

Eases Troubleshooting

- Loopback testing modes, plus SNMP management and LEDs, assist in diagnosing problems on fiber optic networks
- Supports fiber and coax remote loopback control
- Internal test-head function for transmitting and detecting PRBS test patterns.
- LED Line Diagnostics
- Supports Far End Fault (FEF)* - (LineTerm version only)

*FEF provides a local LED indication when a fault exists at the equipment at the far end of the optical link.

Physical Specifications

Fiber Types Supported

- 50/125µm or 62.5/125µm multi-mode fiber
- 9/125µm single-mode fiber
- Available for single-strand fiber

Connectors:

BNC, ST and SC

Regulatory Approvals:

FCC Class B, UL/cUL, CE, CSA, CB

Operating Temperature:

+32° to +122°F (0° to +50°C)

Storage Temperature:

-13° to +158°F (-25° to +70°C)

Humidity:

5 to 95% (non-condensing)

Altitude:

0 to 10,000 ft.

Dimensions

4.19"H x 0.78"W x 2.75"D (10.74 x 2 x 7.05 cm)

Power Rating:

5V

Shipping Weight:

0.30 lbs (0.11 kg)

Ordering Information

iMcV-DS3/E3/STS Repeater Modules

850-14338	iMcV-DS3/E3/STS, BNC/FX-MM850-ST, 2 km
850-14339	iMcV-DS3/E3/STS, BNC/FX-MM850-SC, 2 km
850-14300	iMcV-DS3/E3/STS, BNC/FX-MM1300-ST, 5 km
850-14301	iMcV-DS3/E3/STS, BNC/FX-MM1300-SC, 5 km
850-14302	iMcV-DS3/E3/STS, BNC/FX-SM1310/PLUS-ST, 40 km
850-14303	iMcV-DS3/E3/STS, BNC/FX-SM1310/PLUS-SC, 40 km
850-14304	iMcV-DS3/E3/STS, BNC/FX-SM1310/LONG-ST, 80 km
850-14305	iMcV-DS3/E3/STS, BNC/FX-SM1310/LONG-SC, 80 km
850-14306	iMcV-DS3/E3/STS, BNC/FX-SM1550/LONG-SC, 80 km

Single-Strand Fiber

850-14310	iMcV-DS3/E3/STS, BNC/SSFx-SM1310-SC (1310xmt/1550rcv), 20 km
850-14311	iMcV-DS3/E3/STS, BNC/SSFx-SM1550-SC (1550xmt/1310rcv), 20 km
850-14312	iMcV-DS3/E3/STS, BNC/SSFx-SM1310/PLUS-SC (1310xmt/1550rcv), 40 km
850-14313	iMcV-DS3/E3/STS, BNC/SSFx-SM1550/PLUS-SC (1550xmt/1310rcv), 40 km
850-14314	iMcV-DS3/E3/STS, BNC/SSFx-SM1310/LONG-SC (1310xmt/1550rcv), 80 km
850-14315	iMcV-DS3/E3/STS, BNC/SSFx-SM1550/LONG-SC (1550xmt/1310rcv), 80 km

iMcV-DS3/E3/STS Line Term Modules

850-14438	iMcV-DS3/E3/STS-LineTerm, BNC/FX-MM850-ST, 2 km
850-14439	iMcV-DS3/E3/STS-LineTerm, BNC/FX-MM850-SC, 2 km
850-14400	iMcV-DS3/E3/STS-LineTerm, BNC/FX-MM1300-ST, 2 km
850-14401	iMcV-DS3/E3/STS-LineTerm, BNC/FX-MM1300-SC, 2 km
850-14402	iMcV-DS3/E3/STS-LineTerm, BNC/FX-SM1310/PLUS-ST, 40 km
850-14403	iMcV-DS3/E3/STS-LineTerm, BNC/FX-SM1310/PLUS-SC, 40 km
850-14404	iMcV-DS3/E3/STS-LineTerm, BNC/FX-SM1310/LONG-ST, 80 km
850-14405	iMcV-DS3/E3/STS-LineTerm, BNC/FX-SM1310/LONG-SC, 80 km
850-14406	iMcV-DS3/E3/STS-LineTerm, BNC/FX-SM1550/LONG-SC, 80 km

Single-Strand Fiber

850-14410	iMcV-DS3/E3/STS-LineTerm, BNC/SSFx-SM1310-SC (1310xmt/1550rcv), 20 km
850-14411	iMcV-DS3/E3/STS-LineTerm, BNC/SSFx-SM1550-SC (1550xmt/1310rcv), 20 km
850-14412	iMcV-DS3/E3/STS-LineTerm, BNC/SSFx-SM1310/PLUS-SC (1310xmt/1550rcv), 40 km
850-14413	iMcV-DS3/E3/STS-LineTerm, BNC/SSFx-SM1550/PLUS-SC (1550xmt/1310rcv), 40 km
850-14414	iMcV-DS3/E3/STS-LineTerm, BNC/SSFx-SM1310/LONG-SC (1310xmt/1550rcv), 80 km
850-14415	iMcV-DS3/E3/STS-LineTerm, BNC/SSFx-SM1550/LONG-SC (1550xmt/1310rcv), 80 km

Use with Chassis Platform

iMediaChassis Series, See Page 33
MediaChassis Series, See Page 34
IE-MediaChassis Series, See Page 34

**CWDM version available,
Call IMC Networks for details**



E1-Mux/4, E1-Mux/4+Ethernet

6-YEAR
Comprehensive
Warranty



The iMcV-E1-Mux/4 transports four E1 extensions and one RS-232 serial link over a fiber optic line with optional 1+1 protection and full-bandwidth 10/100 ethernet support.

The iMcV-E1-Mux/4 is a managed modular media converter, installed as a Host/Remote pair, that transports four independent E1 lines over a single or dual fiber optic line. The module is ideal for applications requiring TDM extension, such as remote office PABX connectivity, with optional support for a full bandwidth 10/100BaseT Ethernet connection over the same optical link.

There are two different versions to choose from:

- iMcV-E1-Mux/4: standard version offering one RS-232 port and four E1 extensions over fiber, via a single SFP port (SFP not included)
- iMcV-E1-Mux/4+Ethernet: advanced version offering one RS-232 port and four E1 extensions along with one Ethernet extension over fiber. Dual SFP ports offer 1+1 protection switching on the fiber link

The iMcV-E1-Mux/4 system provides full Operation Administration and Management (OAM) support for the E1, Ethernet, and fiber links from the Host end of the link. The equipment detects, Ethernet, E1 and fiber LOS events as well as degraded lines with full LED indications including a Remote Alarm Indication (RAI) over the fiber link.

Fiber redundancy (1+1) on removable SFP modules offers the enhanced reliability of a protected fiber link while supporting the complete range of optical types and distances. The 1+1 protection system automatically switches to the best fiber line within 50 milliseconds, should one line become impaired or fail.

Both product versions feature an independent serial link (RS-232) which is carried over the same fiber link(s), and can be used for transporting serial traffic from other equipment located at the remote point of presence (POP) back to the central office. Each unit also supports an independent RS-232 console port for local monitoring and configuration of the unit by technical support personnel.

Application Example

In a typical application, a Customer PABX is provided with up to four E1 lines from the Public Switch Telephone Network (PSTN) over a protected optical link. In addition, the customer location can receive a full bandwidth, 100BaseT Ethernet connection to the Internet from the local Internet Service Provider (ISP) over the same, protected, optical link. Operation Administration and Management (OAM) functions for the link are provided from the Host location through either a "Console" RS-232 connection on the Host unit or a SNMP connection through the management interface at the Host chassis. In this example, the RS-232 "Console" port of the remote PABX is also carried back to the Host location for remote management of the customer located PABX, using the end-to-end serial RS-232 port on the iMcV-E1-Mux/4.

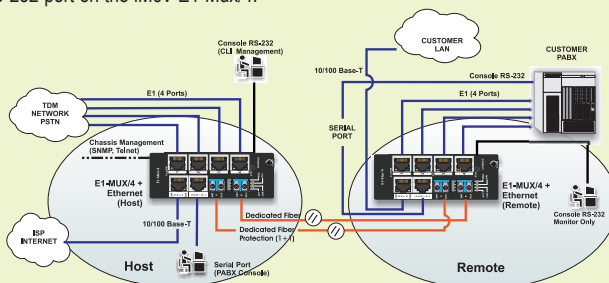

Features

- Four independent E1 ports on RJ-48 connectors
- AIS generation on signal loss on all E1 and fiber interfaces
- Supports local and remote loopback functions
- One optional full bandwidth, Ethernet 10/100BaseT port
- Supports Jumbo Ethernet frames to 1,916
- Supports "Pause" Frames
- Supports the Link Fault Pass-Through Function (LFPT)
- Choice of single SFP fiber port, or dual SFP fiber ports with 1+1 protection switching
- DDMI register retrieval supported on SFP ports for enhanced OAM
- One end-to-end serial RS-232 port to 250 Kbps on an RJ-45 connector
- Command Line Interface (CLI) management provided via one Mini Jack RS-232 console port
- SNMP Alarm TRAP reporting in managed chassis

Physical Specifications

Fiber Types Supported

- SFP

Connectors:

Four RJ-48 E1 ports DTE, 120 ohm
Two SFP sockets
One RS-232 on Mini Jack, One 10/100BaseT on RJ-45
One RS-232 on RJ-45

Regulatory Approvals:

FCC Class B, CE, IEEE-802.3u, ITU-T-G.703 (Pulse Shape), ITU-T-G.775 (AIS, LOS)

Operating Temperature:

+32° to +122°F (0° to +50°C)

Storage Temperature:

-40° to +160°F (-40° to +70°C)

Humidity:

5 to 95% (non-condensing)

Altitude:

0 to 10,000 ft.

Dimensions

Double-wide chassis module

Power Rating:

4.2W Typical 5.5W Max.

Shipping Weight:

1.1 lbs (0.50 kg)

Ordering Information

iMcV-E1-Mux/4 Module (doublewide)

857-14300 iMcV-E1-Mux/4, SFP (requires one SFP/155 Module)

iMcV-E1-Mux/4+Ethernet Module (doublewide)

857-14400 iMcV-E1-Mux/4+Ethernet, SFP (requires one or two SFP/155 Modules)

Use with Chassis Platform

iMediaChassis Series, See Page 33

MediaChassis (2/Slot Only) Series, See Page 34

IE-MediaChassis (2/Slot Only) Series, See Page 34

iMcV-Switch Modules

6-YEAR
Comprehensive
Warranty



Monitor all connections from a central site with iMcV Series multi-port switch modules.

Product Overview

The iMcV-Switch is a multi-port, 10/100 Ethernet module that allows the user to increase port density and the service area of Ethernet networks. The store and forward switch function allows the end user to extend Ethernet service to locations for a total of 100 meters from the Ethernet source. All RJ-45 ports Auto Negotiate 10/100Base-T, half/full duplex, and automatically configure for MDI or MDIX operation. Each port allows a maximum frame size of up to 1916 bytes and supports Flow Control and priority queuing.

Easily view the status of the iMcV-Switch with IMC Networks' GUI-based iView². iView² runs standalone on Windows NT/XP/2000/Vista, as a standalone Java Application for other operating systems, as a snap-in module for HP OpenView, as a Web Server running under IIS or as a Java Web Servlet. For assistance in selecting the right version of iView² for your operating system, visit our web site at: <http://www.imcnetworks.com/products/iView2installers.cfm>

Application Example

The iMcV-Switch allows the user to increase port density and service area of Ethernet networks when installed in an iMediaChassis or MediaChassis. In this example, the iMediaChassis/3-2AC already has an iMcV-VDSL2-LANextender that provides VDSL connectivity while using existing telephone cabling between destinations such as different floors in the same building over a 100 meter range. With the addition of the iMcV-Switch TX/4 + SFP, one now has five more ports, four copper and one fiber, to accommodate varying applications such as UDP video broadcast, data transmission, data access/archiving and SNMP that can be transmitted at a distance via fiber.

Features

- Multi-port 10/100Base-T MAC switch
- Available with 1 or 2 SFP ports, or 1 SC, ST or single-strand fiber port
- Supports up to 1000 MAC address learning
- Supports standard MAC address aging
- Transparent to VLAN tags
- Grants priority for all frames with PRI>4 or DSCP>32
- Supports Auto Cross and Auto Negotiation on all Tx ports
- Supports Flow Control
- Features Collision Detection

Physical Specifications

Fiber Types Supported

- 50/125µm or 62.5/125µm multi-mode fiber
- 9/125µm single-mode fiber
- Available for single-strand fiber

Connectors:

RJ-45 and SC, ST, LC or SFP

Regulatory Approvals:

FCC Class B, UL/cUL, CE

Operating Temperature:

+32° to +122° F (0° to +50° C)

Storage Temperature:

-4° to +158° F (-20° to +70° C)

Humidity:

5 to 95% (non-condensing)

Altitude:

0 to 10,000 ft.

Dimensions

4.19"H x 0.78"W x 2.75"D (10.74 x 2 x 7.05 cm)

Shipping Weight:

0.30 lbs (0.11 kg)

Ordering Information

iMcV-Switch

852-14440	iMcV-Switch, TX/5, 100 m
852-14441	iMcV-Switch, TX/4 + SFP (requires one SFP/155 module),
852-14442	iMcV-Switch, TX/3 + 2SFP (requires SFP/155 module(s))
852-14443	iMcV-Switch, TX/3 + FX-MM850-ST, 2 km
852-14444	iMcV-Switch, TX/3 + FX-MM850-SC, 2 km
852-14445	iMcV-Switch, TX/3 + FX-MM1300-ST, 5 km
852-14446	iMcV-Switch, TX/3 + FX-MM1300-SC, 5 km
852-14449	iMcV-Switch, TX/3 + FX-SM1310/PLUS-ST, 40 km
852-14450	iMcV-Switch, TX/3 + FX-SM1310/PLUS-SC, 40 km
852-14451	iMcV-Switch, TX/3 + FX-SM1310/LONG-ST, 80 km
852-14452	iMcV-Switch, TX/3 + FX-SM1310/LONG-SC, 80 km
852-14453	iMcV-Switch, TX/3 + FX-SM1550/LONG-SC, 80 km
852-14454	iMcV-Switch, TX/3 + FX-SM1550/XLONG-SC, 130 km

Single-Strand Fiber

852-14470	iMcV-Switch, TX/3 + SSFX-SM1310-SC (1310xmt/1550rcv), 20 km
852-14471	iMcV-Switch, TX/3 + SSFX-SM1550-SC (1550xmt/1310rcv), 20 km
852-14472	iMcV-Switch, TX/3 + SSFX-SM1310/PLUS-SC (1310xmt/1550rcv), 40 km
852-14473	iMcV-Switch, TX/3 + SSFX-SM1550/PLUS-SC (1550xmt/1310rcv), 40 km
852-14474	iMcV-Switch, TX/3 + SSFX-SM1310/LONG-SC (1310xmt/1550rcv), 60 km
852-14475	iMcV-Switch, TX/3 + SSFX-SM1550/LONG-SC (1550xmt/1310rcv), 60 km

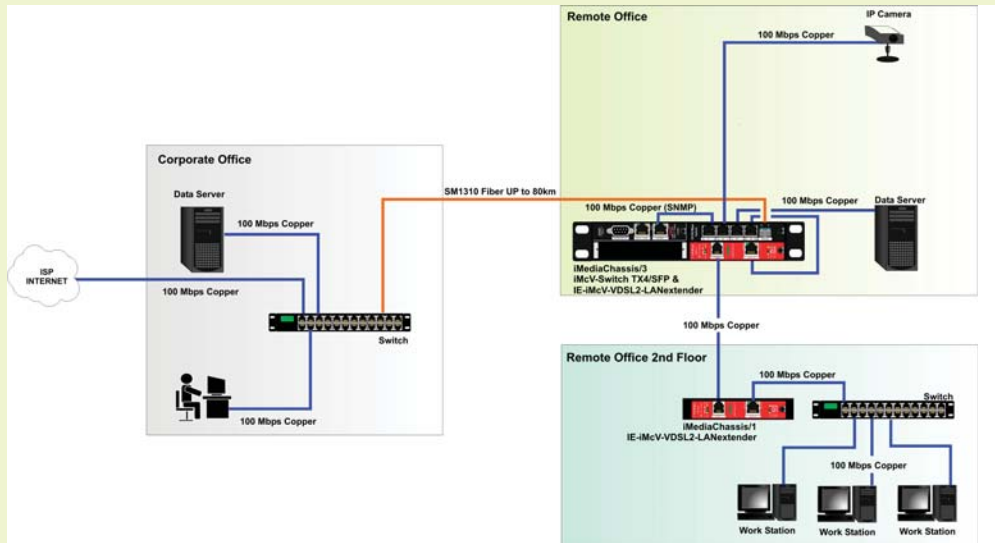



iMcV-PSE-MidSpan



IEEE 802.3af (PoE) compatible, the iMcV-PSE-MidSpan power injector offers unparalleled installation flexibility and cost-savings.

Product Overview

Connecting and powering small devices at the edge of a wired network infrastructure becomes increasingly important to LANs/MANs as they add Wi-Fi access points, webcams, entry control systems and other IP devices. Sometimes, the most optimal location for one of these devices is too far from an AC or DC power source.

IMC Networks' iMcV-PSE-MidSpan provides an important and cost-effective solution. The PSE-MidSpan delivers data and power to Ethernet devices over a single Ethernet cable, using Power over Ethernet (PoE), compliant with IEEE 802.3af. It removes the burden of needing a nearby power outlet and affords greater network flexibility.

The iMcV-PSE-MidSpan can be installed in a multi-port, managed IMC Networks iMediaChassis chassis, when SNMP management is required. The module's compact size is also ideal for installation in a single slot chassis, when space is a consideration and management is not required.

Application Example

The iMcV-PSE-Midspan is ideal for delivering PoE to remote network devices, from a compact rackmountable chassis.

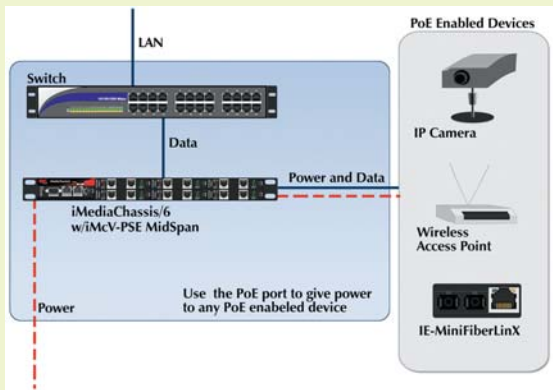

Features

The most cost-effective power injector solution available today

- Provides power to remote network devices
- Quality product Made in America
- Supports Class 1, 2, and 3 powered devices
- Compliant with IEEE 802.3af (Power over Ethernet)

Low Installation Cost

- Avoid separate power and data cable infrastructure and costly AC outlets
- Simple installation means the IT department can do the job - no electrical permits required

Physical Specifications

Fiber Types Supported

- None

Connectors:

RJ-45

Regulatory Approvals:

FCC Class B, CE

Operating Temperature:

+32° to +122°F (0° to +50°C)

Storage Temperature:

-13° to +158°F (-25° to +70°C)

Humidity:

5 to 95% (non-condensing)

Altitude:

0 to 10,000 ft.

Dimensions

4.19"H x 0.78"W x 2.75"D (10.74 x 2 x 7.05 cm)

Power Rating:

3.2A@5V DC Maximum

PoE Output 4, 7 or 15W

Shipping Weight:

0.30 lbs (0.11 kg)

Ordering Information

iMcV-PSE-MidSpan Module

857-14910 iMcV-PSE-MidSpan, 100 m

Use with Chassis Platform

iMediaChassis Series, See Page 33

MediaChassis Series, See Page 34

IE-MediaChassis Series, See Page 34

* Chassis Restrictions:

A 20-slot iMediaChassis supports up to 11 PSE-MidSpans (with AC power) or 9 PSE-MidSpans (with DC power). This applies only to the 20-slot chassis.

For more information contact IMC Networks sales.



IE-iMcV-VDSL2 LANextender Modules



Extend Ethernet services to remote locations or between buildings with Ethernet over Second Generation VDSL.

Product Overview

VDSL Ethernet LAN Extenders enable LAN and campus network managers and service providers to use an existing phone-grade wiring plant to extend 10 Mbps and 100 Mbps Ethernet twisted pair interfaces by using Ethernet over VDSL; the 100 meter distance limitation of twisted pair data cabling is no longer a challenge.

Designed with Second Generation VDSL (Very high-bit-rate Digital Subscriber Line) technology, the IE-iMcV-VDSL2-LANextender allows the transmission of data over sub-standard CAT3 and other telephone cabling to achieve higher data rates than comparable VDSL converters at short distances (less than 100 meters), while supporting asymmetrical data rates on substantially longer lines (greater than 2 km).

IE-iMcV-VDSL2-LANextender modules include:

- One VDSL port with an RJ-11 connector
- One 10/100 twisted pair Ethernet port with a RJ-45 connector
- Auto MDI/MDIX, Auto Negotiation and Selective Advertising with Flow Control on the 10/100 port

Application Example

In this application the IE-iMcV-VDSL2-LANextender provides data transmission using existing phone-grade wiring such as sub-standard CAT3 or other telephone cabling at a distance greater than 100 m when fiber is either too expensive or unavailable. By utilizing existing cabling to transmit data between floors and with the unit's built-in auto adjusting link quality (throughput), and improved fault isolation with Remote Alarm Indicator, Flow Control, and Link Fault Pass-Through, the unit ensures the connection is maintained as well as the ability to quickly troubleshoot when problems do arise.

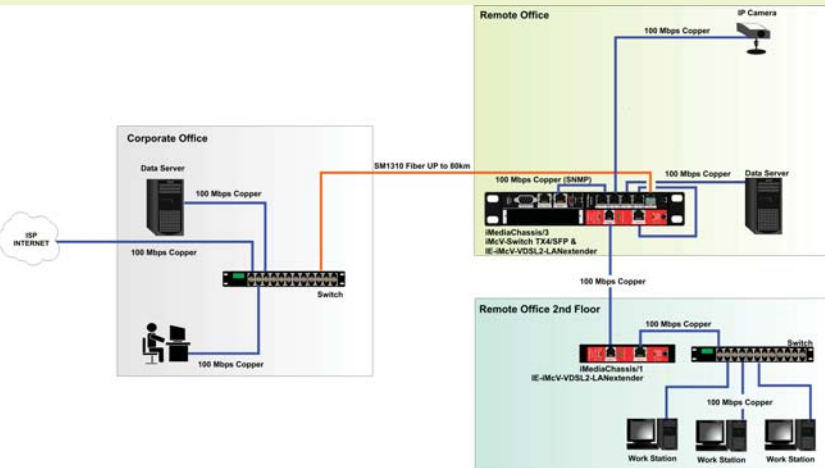

Features

Flexible Solution

- Media and protocol converter - converts 10/100BaseT to VDSL
- Operates over existing CAT3 or other telephone cabling
- Supports VDSL2 for Band Plan 997/998, symmetrical and asymmetrical transmission per ITU-T G.993.2 standard

Easy to configure and manage with GUI-based iView²

- Automatically adjusts to reach best bandwidth performance for the physical line in use
- Monitor and control all connections
- Displays maximum VDSL bandwidth
- User selectable Trap on VDSL bandwidth level

Eases Troubleshooting

- Link Quality LED displays maximum supported bandwidth
- Overflow LED to display congestion on the VDSL line

Physical Specifications

Fiber Types Supported

- N/A

Connectors:

RJ-45 and RJ-11

Regulatory Approvals:

FCC Class B, UL/cUL, CSA, CE

Operating Temperature:

-40° F to 185° F (-40° C to +85° C)

Storage Temperature:

-67° to 257° F (-55° to +125° C)

Humidity:

5 to 95% (non-condensing)

Altitude:

0 to 10,000 ft.

Dimensions

4.19"H x 0.78"W x 2.75"D (10.74 x 2 x 7.05 cm)

Shipping Weight:

0.30 lbs (0.11 kg)

Ordering Information

IE-iMcV-VDSL2 LANextender

851-18200 IE-iMcV-VDSL2-LANextender, Refer to Matrix

Distance	Upstream Data Rate*	Downstream Data Rate*	Upstream Data Rate*	Downstream Data Rate*
	Asymmetrical		Symmetrical	
300 ft.	58 Mbps	100 Mbps	84 Mbps	98 Mbps
1,000 ft.	43 Mbps	85 Mbps	61 Mbps	63 Mbps
2,000 ft.	14 Mbps	50 Mbps	25 Mbps	37 Mbps
5,000 ft.	0.3 Mbps	16 Mbps	0.3 Mbps	16 Mbps

* Distances and speeds are approximate; actual distances depend on wiring quality and gauge. The distances are less than or equal to the values listed.

* The actual Ethernet speeds are lower than the speeds listed above due to VDSL overhead.



iMcV-Mode Converters (iMcV-S2MM, M2MM, S2SM)



The industry's first protocol-independent fiber mode conversion modules convert between dissimilar fiber modes and wavelengths.

Product Overview

The iMcV-S2MM series of fiber mode converters allows easy network extension to remote locations by converting to single-mode fiber— without having to replace existing multi-mode fiber equipment.

Protocol-independent operation means the S2MM series gets the job done: from Ethernet to Fast Ethernet and ATM/OC-3 choose the S2MM/155 series; for OC-12, Gigabit Ethernet and Fibre Channel, choose the S2MM/1250 series. This series also includes multi-mode to multi-mode (M2MM) and single-mode to long-haul single-mode (S2SM) converters for specialty data networking applications.

The iMcV Fiber Mode Converter series is SNMP-manageable to aid in network troubleshooting with modular architecture for flexibility. This series is available with single-strand fiber technology, transmitting two-channel, full duplex data on just one strand of fiber.

Features

- Includes protocol-independent operation
- Converts between dissimilar fiber modes and wavelengths

Three Types of Mode Conversions:

- Single-mode to Multi-mode (S2MM)
- Single-mode to Single-mode (S2SM)
- Multi-mode to Multi-mode (M2MM)

Two Categories of Transmission Speeds:

- /155: Ethernet, Fast Ethernet and ATM/OC-3
- /1250: OC-12, Gigabit Ethernet and Fibre Channel

Physical Specifications

Dimensions

4.19"H x 0.78"W x 2.75"D (10.74 x 2 x 7.05 cm)

Fiber Types Supported

- 50/125µm or 62.5/125µm multi-mode fiber
- 9/125µm single-mode fiber
- Available for single-strand fiber

Shipping Weight:

0.30 lbs (0.11 kg)

Connectors:

ST, SC, LC

Regulatory Approvals:

FCC Class B, CE

Operating Temperature:

+32° to +122°F (0° to +50°C)

Storage Temperature:

-13° to +158°F (-25° to +70°C)

Humidity:

5 to 95% (non-condensing)

Altitude:

0 to 10,000 ft.

Ordering Information

iMcV-S2MM/155 (Single-Mode to Multi-Mode)

850-14520 iMcV-S2MM/155, SM1310/PLUS-ST + MM1300-ST, 40 km + 5 km

850-14530 iMcV-S2MM/155, SM1310/PLUS-SC + MM1300-SC, 40 km + 5 km

850-14540 iMcV-S2MM/155, SM1310/LONG-ST + MM1300-ST, 80 km + 5 km

850-14550 iMcV-S2MM/155, SM1310/LONG-SC + MM1300-SC, 80 km + 5 km

850-14555 iMcV-S2MM/155, SM1550/LONG-SC + MM1300-SC, 80 km + 5 km

850-14560 iMcV-S2MM/155, SM1310/PLUS-ST + MM850-ST, 40 km + 2 km

850-14570 iMcV-S2MM/155, SM1310/PLUS-SC + MM850-SC, 40 km + 2 km

850-14580 iMcV-S2MM/155, SM1310/LONG-ST + MM850-ST, 80 km + 2 km

850-14590 iMcV-S2MM/155, SM1310/LONG-SC + MM850-SC, 80 km + 2 km

850-14595 iMcV-S2MM/155, SM1550/LONG-SC + MM850-SC, 80 km + 2 km

Single-Strand Fiber

850-14532 iMcV-S2MM/155, SSFX-SM1310-SC (1310xmt/1550rcv) + MM1300-SC, 20 km + 5 km

850-14533 iMcV-S2MM/155, SSFX-SM1550-SC (1550xmt/1310rcv) + MM1300-SC, 20 km + 5 km

850-14535 iMcV-S2MM/155, SSFX-SM1310/PLUS-SC (1310xmt/1550rcv) + MM1300-SC, 40 km + 5 km

850-14536 iMcV-S2MM/155, SSFX-SM1550/PLUS-SC (1550xmt/1310rcv) + MM1300-SC, 40 km + 5 km

iMcV-S2MM/622 (Single-mode to Multi-mode)

859-14802 iMcV-S2MM/622, SM1310/PLUS-SC + MM1300-SC, 40 km + 5 km

859-14805 iMcV-S2MM/622, SM1550/LONG-SC + MM1300-SC, 80 km + 5 km

iMcV-S2MM/1250 (Single-mode to Multi-mode)

859-14799 iMcV-S2MM/1250, LX-SM1310-SC + SX-MM850-SC, 15 km + 550 m

859-14800 iMcV-S2MM/1250, LX-SM1310/PLUS-SC + SX-MM850-SC, 40 km + 550 m

859-14801 iMcV-S2MM/1250, LX-SM1550/LONG-SC + SX-MM850-SC, 70 km + 550 m

Single-Strand Fiber

859-14806 iMcV-S2MM/1250, SSLX-SM1310-SC (1310xmt/1550rcv) + SX-MM850-SC, 15 km + 550 m

859-14807 iMcV-S2MM/1250, SSLX-SM1550-SC (1550xmt/1310rcv) + SX-MM850-SC, 15 km + 550 m

859-14808 iMcV-S2MM/1250, SSLX-SM1310/PLUS-SC (1310xmt/1550rcv) + SX-MM850-SC, 40 km + 550 m

859-14809 iMcV-S2MM/1250, SSLX-SM1550/PLUS-SC (1550xmt/1310rcv) + SX-MM850-SC, 40 km + 550 m

iMcV-S2SM (Single-mode to Single-mode)

850-14519 iMcV-S2SM/155, SM1310/PLUS-SC + SM1310/PLUS-SC, 40 km + 40 km

850-14505 iMcV-S2SM/155, SM1310/LONG-SC + SM1310/LONG-SC, 80 km + 80 km

850-14513 iMcV-S2SM/155, SM1550/LONG-SC + SM1310/PLUS-SC, 80 km + 550 m

850-14514-LC iMcV-S2SM/155, SM1550/LONG-SC + SM1310/LONG-LC, 80 km + 80 km

Single-Strand Fiber

850-14515 iMcV-S2SM/155, SSFX-SM1310-SC (1310xmt/1550rcv) + SM1310/PLUS-SC, 20 km + 40 km

850-14516 iMcV-S2SM/155, SSFX-SM1550-SC (1550xmt/1310rcv) + SM1310/PLUS-SC, 20 km + 40 km

850-14517 iMcV-S2SM/155, SSFX-SM1310/PLUS-SC (1310xmt/1550rcv) + SM1310/LONG-SC, 40 km + 80 km

850-14518 iMcV-S2SM/155, SSFX-SM1550/PLUS-SC (1550xmt/1310rcv) + SM1310/LONG-SC, 40 km + 80 km

iMcV-S2SM/1250 (Single-mode to Single mode)

859-14803 iMcV-S2SM/1250, LX-SM1310/PLUS-SC + LX-SM1310/PLUS-SC, 40 km + 40 km

859-14804 iMcV-S2SM/1250, LX-SM1310/PLUS-SC + LX-SM1550/LONG-SC, 40 km + 70 km

Single-Strand Fiber

859-14820 iMcV-S2SM/1250, SSLX-SM1310-SC (1310xmt/1550rcv) + LX-SM1310/PLUS-SC, 15 km + 40 km

859-14821 iMcV-S2SM/1250, SSLX-SM1550-SC (1550xmt/1310rcv) + LX-SM1310/PLUS-SC, 15 km + 40 km

859-14822 iMcV-S2SM/1250, SSLX-SM1310/PLUS-SC (1310xmt/1550rcv) + LX-SM1310/PLUS-SC, 40 km + 40 km

859-14823 iMcV-S2SM/1250, SSLX-SM1550/PLUS-SC (1550xmt/1310rcv) + LX-SM1310/PLUS-SC, 40 km + 40 km

iMcV-M2MM/155 (Multi-mode to Multi-mode)

850-14510 iMcV-M2MM/155, MM1300-ST + MM850-ST, 2 km + 5 km

850-14511 iMcV-M2MM/155, MM1300-SC + MM850-SC, 2 km + 5 km

Use with Chassis Platform

iMediaChassis Series, See Page 33

MediaChassis Series, See Page 34

IE-MediaChassis Series, See Page 34

IE-ModeConverter SFP/SFP



Connect network segments running different fiber types using interchangeable SFP modules.

Product Overview

Mode converters allow network operators to incorporate multiple fiber types within a network. The IE-ModeConverter provides the ability to accomplish this by working with existing equipment and thus, eliminating replacement costs. By converting between single-mode and multi-mode fiber, one can easily extend network range to reach more remote locations. Additionally, since the IE-ModeConverter is an Industrial Ethernet device (IE), the unit operates in environments that demand extended operating temperatures.

The IE-ModeConverter uses SFP modules to provide greater fiber flexibility in the network environment. The hot-swappable nature of the SFPs and the numerous fiber modes and types available in SFPs allow for easy configuration and future upgrading as network demands evolve.

The IE-ModeConverter requires two fiber optic SFP modules to operate. The SFP modules must be MSA compliant and support the same speed range. The IE-ModeConverter operates as a mode converter only and not as a rate converter.

Application Examples

In this example, the IE-ModeConverter converts a local multi-mode fiber signal to a single-mode fiber signal to integrate into an area of the network that supports this type of fiber. The IE-ModeConverter has been equipped with a multi-mode fiber SFP and a single-mode fiber SFP.

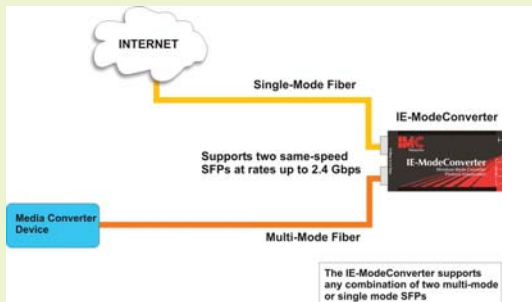

Features

Cost-effective and flexible

- Interchangeable SFP modules allow for multiple fiber mode/type conversion options (single mode, multi-mode, long haul, short haul, etc.)
- Extended operating temperatures
- Multiple mounting options (desktop, DIN rail, IE-PowerTray/18 (for high density installations))
- Compact size conserves space
- AC or DC powering options
- Ideal for use with IMC Networks' SFPs

Protocol-Independent

- Supports a full range of SFP Modules offering various transmission speeds, from 10 Mbps to 2.4 Gbps
- Supports OC3, OC12, OC48

Maximizes network uptime

- SFP Modules are hot-swappable; no need to power-down chassis when upgrading or trouble-shooting a single module

Physical Specifications

Fiber Types Supported

- SFP

Connectors:

SFP Slots

Regulatory Approvals:

FCC Class B, UL/cUL, CSA, CE, CB

Operating Temperature:

+31° to +158°F (-35° to +70°C)

Storage Temperature:

-49° to +185°F (-45° to +85°C)

Humidity:

5 to 95% (non-condensing)

Altitude:

0 to 10,000 ft.

Dimensions

0.83"H x 1.80"W x 3.35"D (2.11 x 4.57 x 8.51 cm)

Power Rating:

AC Wall Adapter: 100-240V AC input, 5V DC output @ 10W, 2.0A

DC Input Voltage: 7 to 50V DC @ 2.5W Chassis grounded to negative terminal

Maximum 3.3W of combined power to both SFPs

Shipping Weight:

0.25 lbs (0.11 kg)

Ordering Information

IE-ModeConverter SFP/SFP with AC Adapter

855-19619 IE-ModeConverter, SFP/SFP

IE-ModeConverter SFP/SFP without AC Adapter

854-19619 IE-ModeConverter, SFP/SFP

Accessories

806-39623 AC Power Adapter for MiniMc products (10 watt, 0°C to +50°C)

806-00322-00 Power Adapter Clip (USA)

806-00322-01 Power Adapter Clip (UK)

806-00322-02 Power Adapter Clip (Europe)

806-00322-03 Power Adapter Clip (Australia/New Zealand)

806-39105 DIN Clip

IE-iMcV-ModeConverter SFP/SFP

6-YEAR
Comprehensive
Warranty



Connect network segments running different fiber types using IMC Networks' interchangeable SFP modules.

Product Overview

The IE-iMcV-ModeConverter is an SNMP manageable module that allows network operators to incorporate multiple fiber types and wavelengths within a network. It installs in the modular, SNMP-manageable iMediaChassis series and in the unmanaged MediaChassis series.

The IE-iMcV-ModeConverters are protocol-independent with dual SFP ports which can provide a single conversion between different wavelengths or single-mode and multimode fiber, single-mode to single-mode fiber or multimode to single-strand single-mode fiber. The IE-iMcV-ModeConverter modules support a variety of user configurable features such as LinkLoss and variable speed SFPs. Additionally, since the IE-iMcV-ModeConverter is an Industrial Equipment (IE) device, the unit operates in environments that demand extended operating temperatures.

The IE-iMcV-ModeConverter uses MSA Compliant SFP modules to provide greater fiber flexibility in the network environment. The hot-swappable nature of SFPs and the numerous fiber modes and types that are available allow for easy configuration and future upgrading as network demands evolve.

Application Examples

In this example, both single-mode and multi-mode fiber are deployed with the IE-iMcV-ModeConverter conveniently and seamlessly located at the origin and destination. The extended temperature range is ideal for the manufacturing location, housed in the unmanaged MediaChassis/1 converting between single-mode and multi-mode fiber for transmission at a distance to another IE-iMcV-ModeConverter, housed in a SNMP-managed iMediachassis/20 along with other modules.

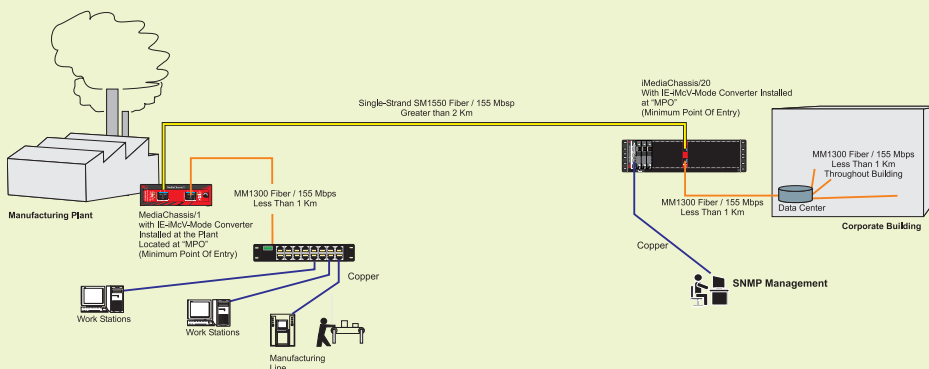

Features

Cost-effective and flexible

- Interchangeable SFP modules allow for multiple fiber mode/type conversion options (single-mode, multi-mode, single-strand, long haul, short haul, etc.)
- Extended operating temperatures
- DDMI enabled SFPs support SNMP when installed in a compatible managed chassis
- Modular, hot-swappable architecture reduces operational costs associated with product installation, upgrades and maintenance
- Ideal for use with IMC Networks' SFPs

Protocol-Independent

- Supports a full range of SFP modules offering various transmission speeds, from 10 Mbps up to 2.4 Gbps*

Maximizes network uptime

- Modules are hot-swappable; no need to power-down chassis when upgrading or troubleshooting a single module
- User selectable FX LinkLoss enables the operator to identify a cable fault/failure to isolate the fault to the specific fiber that has failed

Physical Specifications

Fiber Types Supported

- SFP

Connectors:

SFP Slots

Regulatory Approvals:

FCC Class A, UL/cUL, CE

Operating Temperature:

-40° to +185° F (-40° to +85° C)

Storage Temperature:

-40° to +185° F (-40° to +85° C)

Humidity:

5 to 95% (non-condensing)

Altitude:

0 to 10,000 ft.

Dimensions

4.19" x 0.78" x 2.75" (10.6 cm x 1.98 cm x 6.99 cm)

Power Rating:

Maximum 3.3W of combined power to both SFPs

Shipping Weight:

0.25 lbs (0.11 kg)

Ordering Information

IE-iMcV-ModeConverter SFP/SFP

850-19500

IE-iMcV-ModeConverter, SFP/SFP

IE-SFP 100 to 155 Mbps (OC-3) Modules



Plug in more fiber types and maximize network hardware.

Product Overview

The use of IE-SFP modules makes changing fiber requirements within the locations of the network environment easy. IE-SFPs offer the flexibility of choosing fiber types, and also provide diagnostic information to assist the end user in the identification and troubleshooting of the pluggable modules.

All IE-SFPs are compliant with the Multi-Source Agreement (MSA), ensuring compatibility with a wide range of networking equipment.

All products are made in the USA except SFP products.

Features

Fiber or copper versions available

All SFP Modules

- Multi-source package with Duplex LC connector
- Eye Safety designed to meet Laser Class 1 compliance with IEC 60825-1
- Compliant with ITU-T-G.957, G.958, IEEE 802.3u and 802.3z
- Single +3.3V power supply
- Hot-pluggable
- Complies with Telcordia GR-468-CORE
- All SFP modules report standard information such as:
 - » SFP Type
 - » Fiber Link Length
 - » Wavelength
 - » Bit Rate
 - » Date Code
 - » Serial Number

Extended Diagnostics (DDMI)

- Complying with SFF-8472, IE-SFP modules that include Extended Diagnostics also report information such as:
 - » Temperature
 - » Voltage
 - » Bias Current
 - » TX Power
 - » RX Power

Ordering Information

With DDMI

IE-SFP/155-ED

808-38101	IE-SFP/155-ED, MM850-LC, 2 km
808-38102	IE-SFP/155-ED, MM1300-LC, 2 km
808-38103	IE-SFP/155-ED, SM1310-LC, 15 km
808-38104	IE-SFP/155-ED, SM1310/PLUS-LC, 40 km
808-38105	IE-SFP/155-ED, SM1550/LONG-LC, 80 km

Single-Strand Fiber

808-38121	IE-SFP/155-ED, SSFX-SM1310-SC (1310xmt/1550rcv), 15 km
808-38122	IE-SFP/155-ED, SSFX-SM1550-SC (1550xmt/1310rcv), 15 km
808-38123	IE-SFP/155-ED, SSFX-SM1310/PLUS-SC (1310xmt/1550rcv), 40 km
808-38124	IE-SFP/155-ED, SSFX-SM1550/PLUS-SC (1550xmt/1310rcv), 40 km
808-38125	IE-SFP/155-ED, SSFX-SM1310/LONG-SC (1310xmt/1550rcv), 60 km
808-38126	IE-SFP/155-ED, SSFX-SM1550/LONG-SC (1550xmt/1310rcv), 60 km
808-38127	IE-SFP/155-ED, SSFX-SM1490/XLONG-SC (1490xmt/1550rcv), 80 km
808-38128	IE-SFP/155-ED, SSFX-SM1550/XLONG-SC (1550xmt/1490rcv), 80 km

Without DDMI

IE-SFP/155

808-38111	IE-SFP/155, MM850-LC, 2 km
808-38112	IE-SFP/155, MM1300-LC, 2 km
808-38113	IE-SFP/155, SM1310-LC, 15 km
808-38114	IE-SFP/155, SM1310/PLUS-LC, 40 km
808-38115	IE-SFP/155, SM1550/LONG-LC, 80 km

Single-Strand Fiber

808-38131	IE-SFP/155, SSFX-SM1310-SC (1310xmt/1550rcv), 15 km
808-38132	IE-SFP/155, SSFX-SM1550-SC (1550xmt/1310rcv), 15 km
808-38133	IE-SFP/155, SSFX-SM1310/PLUS-SC (1310xmt/1550rcv), 40 km
808-38134	IE-SFP/155, SSFX-SM1550/PLUS-SC (1550xmt/1310rcv), 40 km
808-38135	IE-SFP/155, SSFX-SM1310/LONG-SC (1310xmt/1550rcv), 60 km
808-38136	IE-SFP/155, SSFX-SM1550/LONG-SC (1550xmt/1310rcv), 60 km
808-38137	IE-SFP/155, SSFX-SM1490/XLONG-SC (1490xmt/1550rcv), 80 km
808-38138	IE-SFP/155, SSFX-SM1550/XLONG-SC (1550xmt/1490rcv), 80 km

Fiber

Operating temperature:

-40°C to +85°C (-40° F to +185° F)

155 Mbps Ethernet SFP Modules

1.25 Gbps Ethernet SFP Modules

2.4 Gbps Ethernet SFP Modules

Copper

Operating temperature:

0°C to +85°C (+32° F to +185° F)

10/100/1000 Mbps SFP Modules

1000 Mbps SFP Modules

With LC Connector

808-38521	IE-SFP/155-ED, SSFX-SM1310-LC (1310xmt/1550rcv), 15 km
808-38522	IE-SFP/155-ED, SSFX-SM1550-LC (1550xmt/1310rcv), 15 km
808-38523	IE-SFP/155-ED, SSFX-SM1310/PLUS-LC (1310xmt/1550rcv), 40 km
808-38524	IE-SFP/155-ED, SSFX-SM1550/PLUS-LC (1550xmt/1310rcv), 40 km
808-38525	IE-SFP/155-ED, SSFX-SM1310/LONG-LC (1310xmt/1550rcv), 60 km
808-38526	IE-SFP/155-ED, SSFX-SM1550/LONG-LC (1550xmt/1310rcv), 60 km
808-38527	IE-SFP/155-ED, SSFX-SM1490/XLONG-LC (1490xmt/1550rcv), 80 km
808-38528	IE-SFP/155-ED, SSFX-SM1550/XLONG-LC (1550xmt/1490rcv), 80 km

Copper (Twisted Pair) Modules

808-39001	SFP/10-1250, TX, 100 m
808-39010	SFP/1250, TX, 100 m

With LC Connector

808-38531	IE-SFP/155, SSFX-SM1310-LC (1310xmt/1550rcv), 15 km
808-38532	IE-SFP/155, SSFX-SM1550-LC (1550xmt/1310rcv), 15 km
808-38533	IE-SFP/155, SSFX-SM1310/PLUS-LC (1310xmt/1550rcv), 40 km
808-38534	IE-SFP/155, SSFX-SM1550/PLUS-LC (1550xmt/1310rcv), 40 km
808-38535	IE-SFP/155, SSFX-SM1310/LONG-LC (1310xmt/1550rcv), 60 km
808-38536	IE-SFP/155, SSFX-SM1550/LONG-LC (1550xmt/1310rcv), 60 km
808-38537	IE-SFP/155, SSFX-SM1490/XLONG-LC (1490xmt/1550rcv), 80 km
808-38538	IE-SFP/155, SSFX-SM1550/XLONG-LC (1550xmt/1490rcv), 80 km

IE-SFP/155 CWDM

808-38161	SFP/155, CWDM-SM1270-LC
-----------	-------------------------

CWDM version available, Call IMC Networks for details

IE-SFP 1250 Mbps/1.25 Gbps (OC-24) Modules



Fiber

Operating temperature:

- 40°C to +85°C (-40° F to +185° F)
- 155 Mbps Ethernet SFP Modules
- 1.25 Gbps Ethernet SFP Modules
- 2.4 Gbps Ethernet SFP Modules

Plug in more fiber types and maximize network hardware.

Product Overview

The use of IE-SFP modules makes changing fiber requirements within the locations of the network environment easy. IE-SFPs offer the flexibility of choosing fiber types, and also provide diagnostic information to assist the end user in the identification and troubleshooting of the pluggable modules.

All IE-SFPs are compliant with the Multi-Source Agreement (MSA), ensuring compatibility with a wide range of networking equipment.

All products are made in the USA except SFP products.

Features

All SFP Modules

- Multi-source package with Duplex LC connector
- Eye Safety designed to meet Laser Class 1 compliance with IEC 60825-1
- Compliant with ITU-T-G.957, G.958, IEEE 802.3u and 802.3z
- Single +3.3V power supply
- Hot-pluggable
- Complies with Telcordia GR-468-CORE
- All SFP modules report standard information such as:
 - » SFP Type
 - » Fiber Link Length
 - » Wavelength
 - » Bit Rate
 - » Date Code
 - » Serial Number

Extended Diagnostics (DDMI)

- Complying with SFF-8472, IE-SFP modules that include Extended Diagnostics also report information such as:
 - » Temperature
 - » Voltage
 - » Bias Current
 - » TX Power
 - » RX Power

Ordering Information

With DDMI

IE-SFP/1250-ED

- 808-38201 IE-SFP/1250-ED, MM850-LC, 550 m
- 808-38206 IE-SFP/1250-ED, MM1300-LC, 2 km 
- 808-38202 IE-SFP/1250-ED, SM1310-LC, 10 km
- 808-38203 IE-SFP/1250-ED, SM1310/PLUS-LC, 30 km
- 808-38204 IE-SFP/1250-ED, SM1550/LONG-LC, 40 km
- 808-38205 IE-SFP/1250-ED, SM1550/XLONG-LC, 70 km

Single-Strand Fiber

- 808-38221 IE-SFP/1250-ED, SSLX-SM1310-SC (1310xmt/1550rcv), 10 km
- 808-38222 IE-SFP/1250-ED, SSLX-SM1550-SC (1550xmt/1310rcv), 10 km
- 808-38223 IE-SFP/1250-ED, SSLX-SM1310/PLUS-SC (1310xmt/1550rcv), 30 km
- 808-38224 IE-SFP/1250-ED, SSLX-SM1550/PLUS-SC (1550xmt/1310rcv), 30 km
- 808-38225 IE-SFP/1250-ED, SSLX-SM1490/LONG-SC (1490xmt/1550rcv), 70 km
- 808-38226 IE-SFP/1250-ED, SSLX-SM1550/LONG-SC (1550xmt/1490rcv), 70 km

Without DDMI

IE-SFP/1250

- 808-38211 IE-SFP/1250, MM850-LC, 550 m
- 808-38212 IE-SFP/1250, SM1310-LC, 10 km
- 808-38213 IE-SFP/1250, SM1310/PLUS-LC, 30 km
- 808-38214 IE-SFP/1250, SM1550/LONG-LC, 40 km
- 808-38215 IE-SFP/1250, SM1550/XLONG-LC, 70 km

Single-Strand Fiber

- 808-38231 IE-SFP/1250, SSLX-SM1310-SC (1310xmt/1550rcv), 10 km
- 808-38232 IE-SFP/1250D, SSLX-SM1550-SC (1550xmt/1310rcv), 10 km
- 808-38233 IE-SFP/1250, SSLX-SM1310/PLUS-SC (1310xmt/1550rcv), 30 km
- 808-38234 IE-SFP/1250, SSLX-SM1550/PLUS-SC (1550xmt/1310rcv), 30 km
- 808-38235 IE-SFP/1250, SSLX-SM1490/LONG-SC (1490xmt/1550rcv), 70 km
- 808-38236 IE-SFP/1250, SSLX-SM1550/LONG-SC (1550xmt/1490rcv), 70 km

CWDM version available,
Call IMC Networks for details

IE-SFP 2.4 Gbps (OC-48) and 10 Gbps (OC-192) Modules



Fiber

Operating temperature:

- 40°C to +85°C (-40° F to +185° F)
- 155 Mbps Ethernet SFP Modules
- 1.25 Gbps Ethernet SFP Modules
- 2.4 Gbps Ethernet SFP Modules

Plug in more fiber types and maximize network hardware.

Product Overview

The use of IE-SFP modules makes changing fiber requirements within the locations of the network environment easy. IE-SFPs offer the flexibility of choosing fiber types, and also provide diagnostic information to assist the end user in the identification and troubleshooting of the pluggable modules.

All IE-SFPs are compliant with the Multi-Source Agreement (MSA), ensuring compatibility with a wide range of networking equipment.

All products are made in the USA except SFP products.

Features

All SFP Modules

- Multi-source package with Duplex LC connector
- Eye Safety designed to meet Laser Class 1 compliance with IEC 60825-1
- Compliant with ITU-T-G.957, G.958, IEEE 802.3u and 802.3z
- Single +3.3V power supply
- Hot-pluggable
- Complies with Telcordia GR-468-CORE
- All SFP modules report standard information such as:
 - » SFP Type
 - » Fiber Link Length
 - » Wavelength
 - » Bit Rate
 - » Date Code
 - » Serial Number

Extended Diagnostics (DDMI)

- Complying with SFF-8472, IE-SFP modules that include Extended Diagnostics also report information such as:
 - » Temperature
 - » Voltage
 - » Bias Current
 - » TX Power
 - » RX Power

Ordering Information

With DDMI

IE-SFP/2.4-ED

- 808-38301 IE-SFP/2.4-ED, MM850-LC, 300 m
- 808-38302 IE-SFP/2.4-ED, SM1310-LC, 2 km
- 808-38303 IE-SFP/2.4-ED, SM1310/PLUS-LC, 15 km
- 808-38304 IE-SFP/2.4-ED, SM1550/LONG-LC, 40 km

Single-Strand Fiber

- 808-38311 IE-SFP/2.4-ED, SSLX-SM1310-LC (1310xmt/1550rcv), 10 km
- 808-38312 IE-SFP/2.4-ED, SSLX-SM1550-LC (1550xmt/1310rcv), 10 km
- 808-38313 IE-SFP/2.4-ED, SSLX-SM1310/PLUS-LC (1310xmt/1550rcv), 20 km
- 808-38314 IE-SFP/2.4-ED, SSLX-SM1550/PLUS-LC (1550xmt/1310rcv), 20 km
- 808-38315 IE-SFP/2.4-ED, SSLX-SM1310/LONG-LC (1310xmt/1550rcv), 40 km
- 808-38316 IE-SFP/2.4-ED, SSLX-SM1550/LONG-LC (1550xmt/1310rcv), 40 km

Without DDMI

IE-SFP/2.4

- 808-38321 IE-SFP/2.4, MM850-LC, 300 m
- 808-38322 IE-SFP/2.4, SM1310-LC, 2 km
- 808-38323 IE-SFP/2.4, SM1310/PLUS-LC, 15 km
- 808-38324 IE-SFP/2.4, SM1550/LONG-LC, 40 km

Single-Strand Fiber

- 808-38331 IE-SFP/2.4, SSLX-SM1310-LC (1310xmt/1550rcv), 10 km
- 808-38332 IE-SFP/2.4, SSLX-SM1550-LC (1550xmt/1310rcv), 10 km
- 808-38333 IE-SFP/2.4, SSLX-SM1310/PLUS-LC (1310xmt/1550rcv), 20 km
- 808-38334 IE-SFP/2.4, SSLX-SM1550/PLUS-LC (1550xmt/1310rcv), 20 km
- 808-38335 IE-SFP/2.4, SSLX-SM1310/LONG-LC (1310xmt/1550rcv), 40 km
- 808-38336 IE-SFP/2.4, SSLX-SM1550/LONG-LC (1550xmt/1310rcv), 40 km

With DDMI

IE-SFP/10 Gbps

- 808-38600 IE-SFP + SR/10G-ED, MM850-LC, 33 m
- 808-38601 IE-SFP+ LR/10G-ED, SM1310-LC, 10 km

With DDMI

IE-XFP/10 Gbps

- 808-38610 IE-XFP SR/10G-ED, MM850-LC, 33 m
- 808-38611 IE-XFP LR/10G-ED, SM1310-LC, 10 km
- 808-38612 IE-XFP ER/10G-ED, SM1550-LC, 40 km

CWDM version available,
Call IMC Networks for details

Managed Chassis

iMediaChassis

The iMediaChassis line provides SNMP management capabilities when used in conjunction with the SNMP Module.



Version	iMediaChassis/20 *	iMediaChassis/6	iMediaChassis/3
# of Slots	20 + 1 SNMP	6 + 1 SNMP	3 + 1 SNMP
Power Specs	Redundant AC and DC Field replaceable AC Power Supply: 100-240V AC, 50/60Hz, 3A/1.5A DC power Supply: -48V DC, 5A ACDC Power: 100-240V AC, 50/60Hz, 2A, -48V DC, 4.4A	Redundant AC and DC Field replaceable AC Power Supply: 100-240V AC, 50/60Hz, 1A DC power Supply: -48V DC, 2A	AC and DC Not field replaceable AC Power Supply: 100-240V AC, 50/60Hz, 0.75A DC power Supply: 35V DC to 75V DC, 1.6A
Regulatory	* For iMediaChassis/20 DC Single & Dual: FCC Class A, UL/cUL, CSA, CE, CB FCC Class B, UL/cUL, CSA, CE, CB		
Operating Temp	+32° to +122°F (0° to +50°C)	AC Temp: -130° to +122°F (-25° to +50°C) DC Temp: -40° to +212°F (-40° to +100°C)	AC Temp: +32° to +122°F (0° to +50°C) DC Temp: -67° to +122°F (-40° to +50°C)
Storage Temp	Dual AC & ACDC Temp: -4° to +176°F (-20° to +80°C) Dual DC Temp: -4° to +140°F (-20° to +60°C)	AC Temp: -40° to +185°F (-40° to +85°C) DC Temp: -55° to +257°F (-55° to +125°C)	AC Temp: -40° to +185°F (-40° to +85°C) DC Temp: -40° to +212°F (-55° to +125°C)
Humidity	5% to 95%, non-condensing, 0 – 10,000 ft altitude		
Dimensions	5.20"H x 19"W x 13.80"D (13.21 cm x 48.26 cm x 35.05 cm)	1.75"H x 17.35"W x 10.65"D (4.45 cm x 44.07 cm x 27.05 cm)	1.73"H x 7.50"W x 8.74"D (4.44 cm x 19.0 cm x 22.0 cm)

iMediaChassis/3	
850-10949-AC	1 fixed AC power supply
850-10949-2AC	2 fixed AC power supplies
850-10949-DC	1 fixed DC power supply
850-10949-2DC	2 fixed DC power supplies
850-10949-ACDC	1 fixed AC and 1 fixed DC power supply

iMediaChassis/6	
850-10953-AC	Includes 1 AC power supply module with option for 2nd power supply
850-10953-2AC	Includes 2 AC power supply modules
850-10953-DC	Includes 1 DC power supply module with option for 2nd power supply
850-10953-2DC	Includes 2 power supply modules

iMediaChassis/20	
850-10954-2DC	Includes 2 DC power supply modules
850-10960-2AC	Includes 2 AC power supply modules 
850-10952-AC	Includes single fixed AC power supply module

The iMediaChassis lines operate with the following IMC Modules:

- iMcV-DS3/E3/STS
- iMcV-FiberLinX-II
- iMcV-Gigabit
- iMcV-Giga-FiberLinX-II
- iMcV-Giga-MediaLinX
- iMcV-LIM
- iMcV-MediaLinX
- iMcV-PIM
- iMcV-PSE-Midspan
- iMcV-T1/E1/J1
- iMcV-E1 Mux/4
- iMcV-E1 Mux/4 + Ethernet
- iMcV-WDM
- iMcV-Mode Converters
- SNMP Management Module

Accessories



SNMP Module	
850-39950	iMediaChassis SNMP Management Module

*An SNMP module is required to utilize full SNMP functionality in the iMediaChassis family.

Serial Cable	
825-39950	Serial Cable, DB9 (Male) to DB9 (Female)



Power Supplies for iMediaChassis/6	
806-39125-AC	PS/125-AC Module, for iMediaChassis/6-AC (125 watt, 100-240 VAC)
806-39125-DC	PS/125-DC Module, for iMediaChassis/6-DC (125 watt, -48 V DC)



Power Supplies for iMediaChassis/20	
806-39400-AC	PS/400-AC Module, for p/n 50-10954-AC, iMediaChassis/20-AC (400 watt, 100-240 VAC)
806-39401-AC	PS/401-Dual-AC Module, for p/n 850-10956-AC, iMediaChassis/20-2AC
806-39960-AC	PS/960-AC Power Module, for p/n 850-10960-2AC, iMediaChassis/20-2AC (100-240 VAC) 
806-39300-DC	PS/300-Dual-DC Module, for iMediaChassis/20-Dual-DC (300 watt, -48 V DC)

Unmanaged Chassis

MediaConverter



The MediaConverter lines operate with the following IMC Modules:

- McPIM TP/FO
- McLIM TX/FX and TX/SX
- McLIM TP-TX/FX and TP TX/SX
- McGigabit TX/SX and TX/LX

Version	1-Slot	4-Slot	8-Slot	12-Slot AC
Part Number	851-10901	851-10904	851-10908	851-10912
AC/DC	AC	AC	AC	AC
Power Supply	115-230V AC, 50/60Hz, 0.3/0.15A	120-240V AC, 50/60Hz, 1.0/0.5A	100-250V AC, 50/60Hz, 1.6A	115-230V AC, 50/60Hz, 1.2/0.6A
Regulatory	FCC Class A, UL/CUL, CE, CSA			
Operating Temp	+32° to +122°F (0° to +50°C)			
Storage Temp	-13° to +158°F (-25° to +70°C); 5 to 95% (non-condensing)			
Humidity	5% to 95%, non-condensing, 0 – 10,000 ft altitude			
Dimensions	1.60"H x 4.75"W x 5.20"D (4.06 x 12.07 x 13.21 cm)	1.75"H x 8.60"W x 4.73"D (8.3 x 21.84 x 12.01 cm)	1.75"H x 17.4"W x 4.70"D (4.45 x 44.20 x 11.94 cm)	1.75"H x 17.40"W x 8.76"D (4.45 x 44.20 x 22.25 cm)
Weight	2 lbs (0.9 kg)	3.5 lbs (1.6 kg)	6.25 lbs (2.8 kg)	11.0 lbs (5 kg)
Mounting	NA	Shelf (Sold Separately)	Brackets Included	Brackets Included

The MediaChassis and IE-MediaChassis lines operate with all the iMcV-Modules

	MediaChassis		IE-MediaChassis (extended operating temperature)			
Version	I/1-AC	I/2-AC	I/1-AC	I/1-DC	I/2-AC	I/2-DC
Part Number	850-13100	850-13101	850-33100	850-32105	850-13106	850-32106
AC/DC	AC	AC	AC/DC	DC	AC	DC
Power Supply	100-240V AC, 50/60Hz, 1A Internal AC Power Supply		DC Terminal: 7-50V DC, 3A-0.1A (Negative ground referenced)	35-75V DC, 500mA, Internal DC Power Supply	100-240V AC, 50/60Hz, 1A Internal AC Power Supply	35-75V DC, 1.5A (Negative ground referenced) Internal DC Power Supply
Regulatory	FCC Class A, UL/CUL, CE, CSA, CB	FCC Class B, UL/CUL, CE, CSA	FCC Class B, UL/CUL, CE, CSA	FCC Class B, UL/CUL, CE, CSA, CB	FCC Class A, UL/CUL, CE, CSA, CB	
Operating Temp	+32° to +122°F (0° to +50°C)		-40° to +158°F (-40° to +70°C) with AC wall adapter +32° to +122°F (0° to +50°C)		-31° to +176°F (-35° to +80°C)	
Storage Temp	-40° to 185°F (-40° to 85°C)					
Humidity	5% to 95%, non-condensing, 0 – 10,000 ft altitude					
Dimensions	1.55"H x 4.75"W x 7.31"D (3.94 cm H x 12.07 cm W x 18.57 cm D)	2.2"H x 4.75" W x 7.3"D (5.6 cm H x 12.1 cm W x 18.5 cm D)	0.90"H x 4.30" W x 4.00"D (2.29 cm H x 10.92 cm W x 10.16 cm D)	1.55"H x 4.75"W x 7.31"D (3.94 cm H x 12.07 cm W x 18.57 cm D)	2.2"H x 4.75" W x 7.3"D (5.6 cm H x 12.1 cm W x 18.5 cm D) 2.2"H x 4.75" W x 7.3"D (5.6 cm H x 12.1 cm W x 18.5 cm D)	
Weight	1.6 lbs (0.73 kg)	1.9 lbs (0.86 kg)	0.6 lbs (0.27 kg)	1.6 lbs (0.73 kg)	1.9 lbs (0.86 kg)	

Accessories

Part Number	Accessories for MediaChassis
895-39226	McBasic/MediaChassis/McCCTV Rackmount Brackets
895-39227	McBasic/MediaChassis/McCCTV Wallmount Brackets
895-39949	Rackmount shelf for iMediaChassis/3, McBasic, MediaChassis, AccessEtherLinX and McCCTV
Accessories for MediaConverter Chassis	
806-39040	PS/40x-AC (40 watt, 100 to 240 VAC input)



Types of Fiber Connectors



The ST Connector
Which uses a bayonet locking system is the most common connector.



The SC Connector
Has a molded body and a push-pull system.



The LC Connector
Is a small-form-factor connector, features a ceramic ferrule and looks like a mini SC connector.



The MT-RJ Connector
Is a small-form RJ-style connector, features a molded body and uses a cleave-and-leave splicing.



The FC Connector
Is a threaded connector used in high-vibration environments.



The MTO Connector
Is a connector that uses high-fiber-count ribbon cable. Used in high-density fiber applications.



The MTP Connector
Is a connector that uses high-fiber-count ribbon cable. Used in high-density fiber applications.



The MU Connector
Resembles the larger SC connector, but it's much smaller. It uses the simple push-pull latching connection. Used in high-density fiber applications.

Fiber Optic Cable Construction

Jacket: Usually constructed of extruded PVC. Protects fiber, allows easy handling.

Strengthening fibers: Aramid yarn (Kevlar)

Coating: 900 μm plastic, coats and protects the fiber.

Fiber



Multimode vs. Singlemode Total Internal Reflection

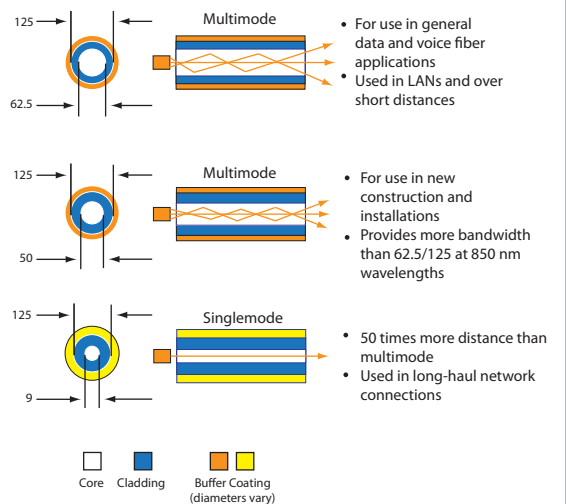

Fiber Performance Standards

Fiber Type	Wavelength	Attenuation (dB/km) Max.	Bandwidth (MHz/km)
Multimode			
50-/125-Micron	850 nm	3.5	500
	1300 nm	1.5	500
62.5-/125-Micron	850 nm	3.5	160
	1300 nm	1.5	500
Singlemode			
Premises	1310 nm	1.0	—
	1550 nm	1.0	—
Outside Plant	1310 nm	0.5	—
	1550 nm	0.5	—

Types of Modular Jacks

6-Position 4 Contact (RJ-11)

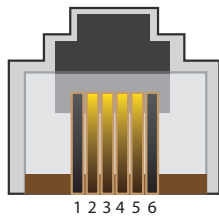

6-Position 6 Contact (MMJ)

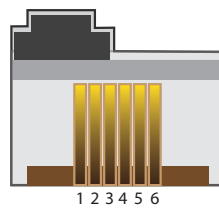

8-Position 8 Contact (RJ-45)

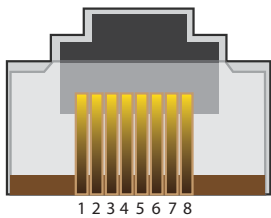

8-Position 8 Contact Keyed (RJ-45)

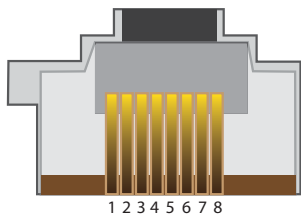

T568A, T568B and USOC Wiring

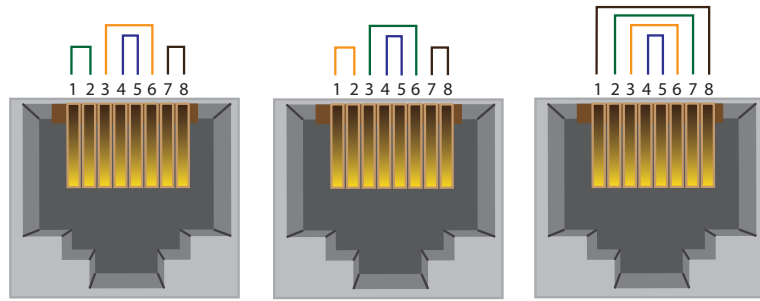

T568A

T568B

USOC

Pair 1 —
Pair 2 —

Pair 3 —
Pair 4 —

Straight-Pinned and Crossover Cable

Straight-pinned cable has the most common type of pinning. The send and receive pairs are wired straight through on either end of the cable.

Crossover cable is generally used for peer-to-peer connections. The send and receive pairs are crossed between Connector A to Connector B on either end of the cable.

T568A and T568B Crossover Cable			USOC Crossover Cable		
Connector (A)		Connector (B)	Connector (A)		Connector (B)
1	—	3	1	—	8
2	—	6	2	—	7
3	—	1	3	—	6
4	—	2	4	—	5
5	—	4	5	—	4
6	—	5	6	—	3
7	—	8	7	—	2
8	—	7	8	—	1

Balanced Twisted-Pair Cable Specifications

	CAT5	CAT5e	CAT6	CAT6a	CAT7(Proposed)
Frequency	100 MHz	100 MHz	250 MHz	500 MHz	600 MHz
Attenuation (Min. at 100 MHz)	22.0 dB	22.0 dB	19.8 dB	—	20.8 dB
Characteristic Impedance	100 ohms ± 15%	100 ohms ± 15%	100 ohms ± 15%	—	100 ohms ± 15%
NEXT (Min. at 100 MHz)	32.3 dB	35.3 dB	44.3 dB	27.9 dB	62.1 dB
PS-NEXT (Min. at 100 MHz)	—	32.3 dB	42.3 dB	—	59.1 dB
EL-FEXT (Min. at 100 MHz)	—	23.8 dB	27.8 dB	9.3 dB	(not yet specified)
PS-ELFEXT (Min. at 100 MHz)	—	20.8 dB	24.8 dB	—	(not yet specified)
PS-ANEXT (Min. at 500 MHz)	—	—	—	49.5 dB	—
PS-AELFEXT (Min. at 500 MHz)	16.0 dB	20.1 dB	20.1 dB	23.0 dB	14.1 dB
Return Loss (Min. at 100 MHz)	16.0 dB	20.1 dB	20.1 dB	8.0 dB	14.1 dB
Delay Skew (Max. per 100 m)	—	45 ns	45 ns	—	20 ns
Networks Supported	100BASE-TX	1000BASE-T	1000BASE-T	10GBASE-T	(not yet specified)

NOTE: The ISO currently has Class F (Category 7a) requirements under development. They are based on Class F requirements and the Category 7 non-RJ style plug. They specify a bandwidth of 600 to 1000 MHz.

IMC Networks Glossary

Term	Converts from:	To:	Notes
10/100	10 or 100 Mbps Copper (10BASE-T or 100BASE-TX)	10 or 100 Mbps Fiber (10BASE-FL or 100BASE-SX)	Auto Sensing media converter only
10/100-SSFX	10 or 100 Mbps Copper (10/100BASE-TX)	10 or 100 Mbps Fiber (10BASE-FL or 100BASE-FX)	Media converter only, single-strand fiber (transmit and receive on same strand); 1310/1550nm, Single-Mode
BNC/FX	Coaxial (BNC)	Protocol Independent Fiber	TDM Converter (DS3/E3)
BNC/SSFX	Coaxial (BNC)	Protocol Independent Fiber	TDM Converter (DS3/E3)
FX	N/A	N/A	100Base-FX Fiber
LX	N/A	N/A	Single-Mode fiber carrying 622 Mbps to 1.25 Gbps (OC-48)
M2MM	Protocol Independent Fiber (Multi-mode)	Protocol Independent Fiber (Multi-mode)	Mode converter
S2MM	Protocol Independent Fiber (Single-mode)	Protocol Independent Fiber (Multi-mode)	Mode converter
S2SM	Protocol Independent Fiber (Single-mode)	Protocol Independent Fiber (Single-mode)	Mode converter
SFP/1250	1.25 Gbps fiber (LC)	SFP	Standard diagnostics
SFP/1250-ED	1.25 Gbps fiber (LC)	SFP	Extended diagnostics
SFP/155	100 - 155 Mbps fiber (LC)	SFP	Standard diagnostics
SFP/155-ED	100 - 155 Mbps fiber (LC)	SFP	Extended diagnostics
SFP/2.4	2.4 Gbps fiber (LC)	SFP	Standard diagnostics
SFP/2.4-ED	2.4 Gbps fiber (LC)	SFP	Extended diagnostics
SFP/SFP	SFP	SFP	
SSFX	N/A	N/A	Single-Strand 100Base-FX Fiber, single mode
SSFX	10 Mbps to 155 Mbps, single or multi-mode	Protocol Independent Fiber, single mode	Single-Strand mode converters
SSLX	622 Mbps to 1.25 Gbps, single or multi-mode	Protocol Independent Fiber, single mode	Single-Strand mode converters
SX			Used with 622 Mbps ATM (OC-12) to 1.25 Gbps
TP/BNC	10 Mbps Copper (10BASE-T)	10 Mbps Coaxial (BNC) (10BASE-2)	Media converter only
TP/Fiber	Twisted Pair (RJ-48)	Protocol Independent Fiber	TDM Converter (T1/E1/J1)
TP/FO	10 Mbps Copper (10BASE-T)	10 Mbps Fiber (10BASE-FL)	Media converter only
TP/SSFiber	Twisted Pair (RJ-48)	Protocol Independent Fiber	TDM Converter (T1/E1/J1)
TP-TX/FX	10 or 100 Mbps Copper (10/100BASE-TX)	100 Mbps Fiber (100BASE-FX)	Media and rate converter
TP-TX/FX-CWDM	10 or 100 Mbps Copper (10/100BASE-TX)	100 Mbps Fiber (100BASE-FX)	Media and rate converter, Single-Mode CWDM
TP-TX/SSFX	10 or 100 Mbps Copper (10/100BASE-TX)	100 Mbps Fiber (100BASE-FX)	Media and rate converter, single-strand fiber (transmit and receive on same strand); 1310/1550nm, single mode
TP-TX/SX	10 or 100 Mbps Copper (10/100BASE-TX)	100 Mbps Fiber (100BASE-SX)	Media and rate converter
TX	N/A	N/A	Copper
TX/3	N/A	N/A	Media and rate converter, three copper ports
TX/3+FX	10 or 100 Mbps Copper (10/100BASE-TX)	100 Mbps Fiber (100BASE-FX)	Media and rate converter, three copper ports to fiber

IMC Networks Glossary (Cont)

Term	Converts from:	To:	Notes	Products Using term
TX/3+SSFX	10 or 100 Mbps Copper (10/100BASE-TX)	100 Mbps Fiber (100BASE-FX)	Media and rate converter, three copper ports to single-strand fiber, single mode	PD-Switch
TX/3+SX	10 or 100 Mbps Copper (10/100BASE-TX)	100 Mbps Fiber (100BASE-SX)	Media and rate converter, three copper ports to fiber	PD-Switch
TX/4	N/A	N/A	Media and rate converter, four copper ports	AccessEtherLinX
TX/4+SFP	10 or 100 Mbps Copper (10/100BASE-TX)	SFP	Media and rate converter, four copper ports to SFP	PD-Switch
TX/5	N/A	N/A	Media and rate converter, four copper ports	PD-Switch
TX/FX	100 Mbps Copper (100BASE-TX)	100 Mbps Fiber (100BASE-FX)	Media converter only	McBasic, McLIM, iMcV-LIM, PSE-McBasic, PSE-XT-McBasic
	10 or 100 Mbps Copper (10BASE-T or 100BASE-TX)	100 Mbps Fiber (100BASE-FX)	Autosensing media converter and rate converter	iMcV-FiberLinX-II, iMcV-MediaLinX
TX/LX	1000 Mbps Copper (1000BASE-T)	1000 Mbps Fiber (1000BASE-LX)	Media converter only, single mode fiber, 1310 or 1550nm	MiniMc-Gigabit, McBasic Gigabit, McPC-Gigabit, McGigabit, iMcV-Gigabit
	10, 100 or 1000 Mbps Copper (10/100/1000BASE-T)	1000 Mbps Fiber (1000BASE-LX)	Media and rate converter, single mode fiber, 1310 or 1550nm	iMcV-Giga-FiberLinX-II, Giga-MiniMc, IE-Giga-MiniMc, iMcV-Giga-MediaLinX
TX/SSFX	100 Mbps Copper (100BASE-TX)	100 Mbps Fiber (100BASE-FX)	Media converter only, single-strand fiber (transmit and receive on same strand); 1310/1550nm, single mode	McBasic, McLIM, iMcV-LIM, PSE-McBasic, PSE-XT-McBasic
	10 or 100 Mbps Copper (10/100BASE-TX)	100 Mbps Fiber (100BASE-FX)	Media and rate converter, single-strand fiber (transmit and receive on same strand); 1310/1550nm, single mode	iMcV-FiberLinX-II, iMcV-MediaLinX
TX/SSLX	1000 Mbps Copper (1000BASE-T)	1000 Mbps Fiber (1000BASE-LX)	Media converter only, single-strand fiber (transmit and receive on same strand); 1310/1550nm up to 40 km; 1490/1550nm over 40 km, single mode	MiniMc-Gigabit, McBasic-Gigabit, McPC-Gigabit, McGigabit, iMcV-Gigabit
	10, 100 or 1000 Mbps Copper (10/100/1000BASE-T)	1000 Mbps Fiber (1000BASE-LX)	Media and rate converter, single-strand fiber (transmit and receive on same strand); 1310/1550nm up to 40 km; 1490/1550nm over 40 km, single mode	iMcV-Giga-FiberLinX-II, Giga-MiniMc, iMcV-Giga-MediaLinX
TX/SX	100 Mbps Copper (100BASE-TX)	100 Mbps Fiber (100BASE-SX)	Media converter only, multi-mode fiber, 850nm	McBasic, McLIM, McPC, iMcV-LIM, PSE-McBasic
	10 or 100 Mbps Copper (10BASE-T or 100BASE-TX)	100 Mbps Fiber (100BASE-SX)	Media and rate converter, multi-mode fiber, 850nm	iMcV-MediaLinX
	1000 Mbps Copper (1000BASE-T)	1000 Mbps Fiber (1000BASE-SX)	Media converter only, multi-mode fiber, 850nm	MiniMc-Gigabit, McBasic-Gigabit, McPC-Gigabit, McGigabit, iMcV-Gigabit
	10, 100 or 1000 Mbps Copper (10/100/1000BASE-T)	1000 Mbps Fiber (1000BASE-SX)	Media and rate converter, multi-mode fiber, 850nm	iMcV-Giga-FiberLinX-II, Giga-MiniMc, IE-Giga-MiniMc, iMcV-Giga-MediaLinX
TX/SFP	Copper	SFP		iMcV-FiberLinX-II, iMcV-Giga-FiberLinX-II
TX/TX	N/A	N/A	Copper to copper (all copper)	iMcV-FiberLinX-II
TX+FX-CWDM	10, 100 or 1000 Mbps Copper (10/100/1000BASE-T)	1000 Mbps Fiber	Media and rate converter, single mode CWDM	iMcV-Giga-FiberLinX-II



www.imcnetworks.com

IMC Networks
Headquarters/Western US
19772 Pauling
Foothill Ranch, CA 92610
TEL: 949-465-3000
FAX: 949-465-3020
sales@imcnetworks.com

IMC Networks
Eastern US/Latin America
Corporate Square
28050 US 19 North, Suite 306
Clearwater, FL 33761
TEL: 727-797-0300
FAX: 727-797-0331
latinsales@imcnetworks.com

IMC Networks
Europe
Herseltsesteenweg 268
B-3200 Aarschot Belgium
TEL: +32-16-550880
FAX: +32-16-550888
eurosales@imcnetworks.com

